

GSV-tested

AluStar tested by a neutral test institute.
Güteschutzverband Betonschalungen (Quality
Protection Association for Concrete Formwork)

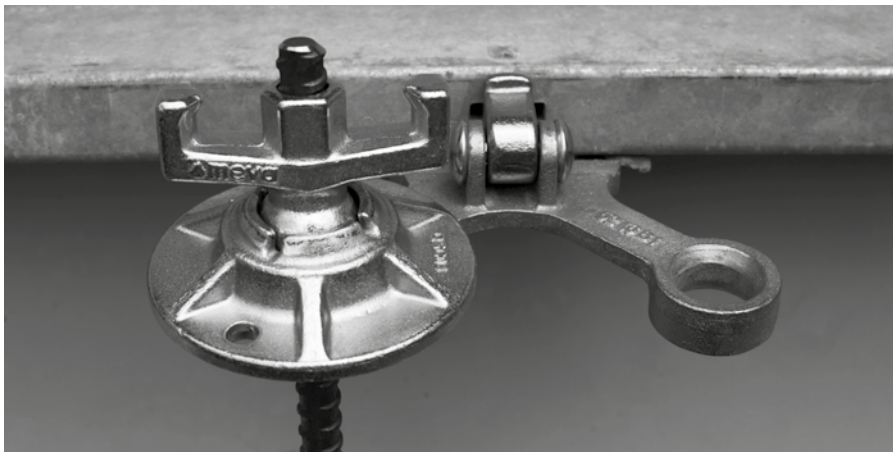
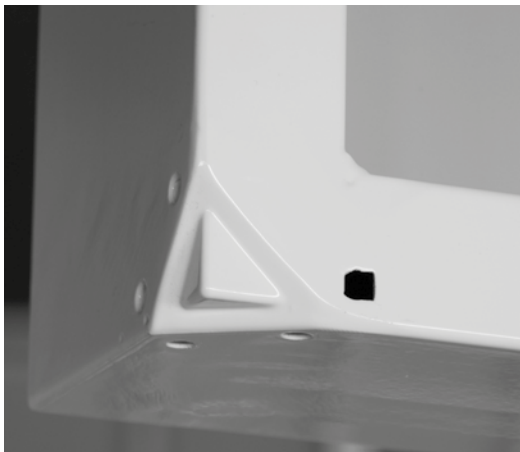

StarTec / AluStar

Technical Instruction Manual



Product features

The StarTec/AluStar wall formwork is a frame formwork system made of robust steel (StarTec) and crane-independent aluminium panels (AluStar).

Both systems can be freely combined without the need for adapters or other additional fasteners.

They are ideally suited for varying types of building projects in the housing and commercial construction sectors and ideal systems for small and medium-sized construction companies.

The steel frames of the StarTec panels are hot-dip galvanised both internally and externally and post-treated. The aluminium frames of the AluStar panels have a high-quality cured powder coating. Both types of coating ensure improved corrosion protection, making them durable and easy to clean.

The MEVA multi-function profile with welded-in DW-threaded nuts makes the attachment of accessories easier, for example:

- Push-pull props and alignment rails with flange screws
- Walkway brackets with integrated self-locking pin
- DW tie rods of any length that are used to bridge problem areas.

The StarTec and AluStar panels are equipped with a 17 mm thick alkus all-plastic facing. StarTec panels with a width of 135 and 240 cm have a 20 mm alkus all-plastic facing. The tried-and-tested polypropylene and aluminium composite facing has all the positive properties of plywood plus important advantages: longer lifespan, greater load-bearing capacity, better nail-holding ability, fewer and easier repairs, 100% recyclability.

The permissible fresh-concrete pressure for the StarTec and AluStar systems is 60 kN/m². The fresh-concrete pressure for vertical formwork according to DIN 18218:2010-01 can be determined easily and precisely with MEVA's online concrete pressure calculator available at www.meva.net.

Abbreviations, measurements, figures and tables, etc.

The abbreviation ST is used for the StarTec series and the abbreviation AS for the AluStar series. DIN means Deutsche Industrie-Norm (German Industrial Standard). E DIN (E = Entwurf / draft) means that the DIN is in draft status and not yet approved. Any further abbreviations are explained where they are used for the first time.

TÜV means Technischer Überwachungsverein. This is the independent German organisation that tests the safety of technical installations, machinery and motor vehicles. If a product passes the test, it is permitted to carry the GS seal. GS stands for Geprüfte Sicherheit (approved safety).

Measurements: This manual uses the metric system, i.e. m (for metre), cm (for centimetre) and mm (for millimetre).

Non-defined dimensions are in cm.

The page numbers in this manual start with ST/AS. The figures and tables are numbered per page. Depending on its product abbreviation, a cross reference in the text refers to a page, table or figure in this or in another manual. This is indicated by the product code with which the cross-reference begins.



Please note

This Technical Instruction Manual contains information, instructions and tips that describe how to use the MEVA equipment on the construction site in a proper, quick and economic way. Most examples shown are standard applications that will occur in practice most often. For more complicated or special applications not covered in this manual, please contact the MEVA experts for advice. They will help you without delay.

When using our products, the federal, state and local occupational health and safety regulations must be observed. Please observe the assembly instructions that your local contractor or employer has created for the site on which the MEVA equipment is used. Such instructions are intended to minimise site-specific risks and must contain the following details:

- The order in which all working steps including assembly and disassembly must be carried out
- The weight of the panels and other system parts
- The type and number of ties and braces as well as the distance between them
- The location, number and dimensions of working scaffolds including the working area and fall protection equipment required
- Attachment points for panel transport by crane. With regard to panel transport, please observe this manual. Any deviation will require structural verification.

Important: Generally, only well-maintained material may be used. Damaged parts must be replaced. Use only original MEVA spare parts for replacement.

Attention: Never wax or oil assembly locks!

Contents

Formwork assembly and stripping.....	4
The StarTec panel	8
The AluStar panel	10
The alkus all-plastic facing	11
Panel connection	12
Placing of ties	13
Rules for concrete pouring and rate of placing.....	14
Flatness of surface	15
Attachment of accessories	16
Wall braces	17
Working scaffolds – Folding access platform BKB 125.....	19
Working scaffolds / walkway brackets	21
Working scaffold – Ladder fixture for wall formwork	22
Fall protection – Tilting bracket 40/60.....	23
Crane hook.....	24
Inside corner 90°	25
Outside corner 90°	26
90° outside corner with side lengths 10 cm and 5 cm.....	27
Height-extended 90° outside corner	28
90° corner with filler.....	29
90° corner – combinations.....	30
Hinged corners	31
Stripping corner.....	33
Length compensation	40
T wall connection	42
Connection to existing walls	43
Stop ends	44
Wall offset.....	46
Pilasters	47
Differences in height.....	48
Horizontal panels.....	49
Substitution of ties.....	50
Height extension.....	51
Crane ganging	54
Crane ganging – Method 1	55
Crane ganging – Method 2	56
Crane ganging – Method 3	57
Crane ganging – Method 4.....	58
Crane ganging – Method 5.....	59
Crane ganging	60
StarTec column formwork.....	62
AluStar column formwork.....	63
Multi-purpose panel	64
Corner solutions with multi-purpose panels	66
Panel with filling nozzle / concreting window.....	68
Circular formwork.....	69
Further applications	71
Transport	72
Services	75
Product list	77

Formwork assembly and stripping

Important!

When assembling and stripping formwork, strictly observe the local accident prevention rules. When using our formwork and systems always observe federal, state and local codes and regulations.

Attention

- During the entire assembly and stripping process vertical panels must be supported or secured against toppling by other means. This applies to all panel types, hence also to corner panels, curved panels, etc.
- Above a formwork height of 2.00 m both sides of the formwork must be secured against falling.

Planning

If you want to benefit fully from the efficient and economical use that the formwork offers, we recommend you first plan and prepare its use. Start planning by determining the optimum formwork quantity to be held in stock (the quantity is usually based on the amount of formwork required for a one day's work). When determining the quantity, consider the following:

- The formwork weight
- The time required for formwork assembly and stripping
- Transport of gangs from one pour to the next considerably reduces assembly and stripping effort and time
- Capacity of the lifting devices
- A logical cycle plan that takes corner configurations, reinforcements, etc. into account

Once all these aspects have been considered, the quantities of formwork material can be specified.

Ground

The ground on which the

formwork is going to be placed should be clean, even and capable of bearing the expected load, as this will help reduce the time required for the assembly and stripping.

Panel transport

When unloading panels or moving panel stacks, make sure to use appropriate transport devices that can bear the load. For details see pages ST/AS-7 to -74.

The steps required for assembly

For ergonomic reasons the outside formwork is usually assembled and placed first. Start the assembly in a corner or at a determined point and perform the following steps:

Step 1 – Place and brace the outside formwork

Step 2 – Define and mark the pouring height, install the reinforcements and boxouts

Step 3 – Place the inside formwork and tie the outside and inside formwork

Refer to the following pages for a detailed description of these steps including the installation of the working platform and formwork stripping.

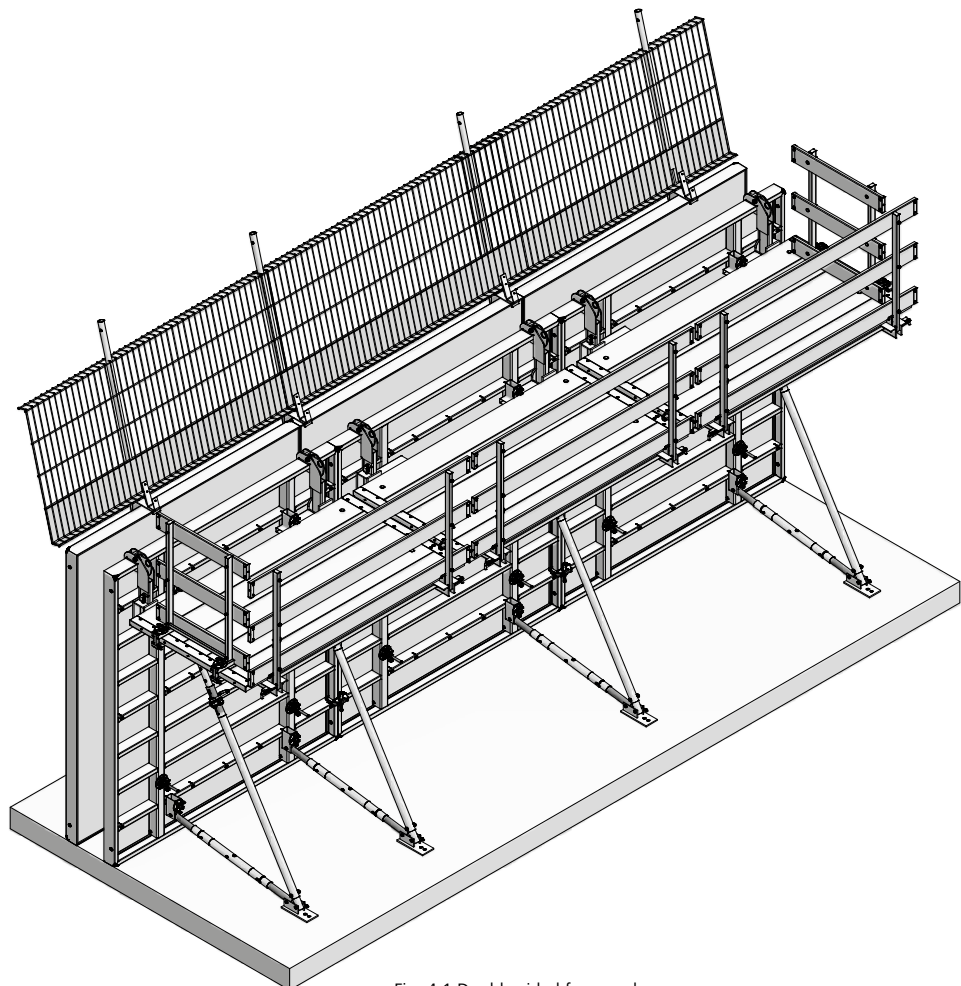

Fig. 4.1 Double-sided formwork

Formwork assembly and stripping

Step 1

Place and brace the outside formwork

The following description is based on a straight wall. Before starting, keep in mind:

- When pre-assembling large panel units on an even surface, attach the wall braces and the walkway bracket as well, i.e. before performing step 1.
- Walls of less than 6 m require a filler for easy stripping (Fig. 5.3), as the formwork may otherwise become wedged and stick to the concrete when it is stripped.

1. Spray the facing with the release agent MevaTrenn pro.
2. Place the first panel and immediately attach it to the ground or concrete slab with two brace frames to prevent it falling over (Fig. 5.1). The foot plate must be firmly connected to the ground or concrete slab – in earth with two ground pegs, in concrete with two heavy-duty dowels.

After placing vertical panels, always reinforce them immediately with push-pull props or brace frames so they can withstand tensile and compressive forces and are protected against displacement and wind. The prop spacing is determined by the application.

If the walkway bracket was not pre-assembled before step 1, you can now assemble and install the working platform. Fig. 1 on page ST/AS-6 shows a working platform being lifted with a crane for attachment to a braced outside formwork.

3. String further panels together and connect them with AS assembly locks (see page ST/AS-12).
The panels are usually connected

with two assembly locks.

However, outside corner configurations require three assembly locks (see pages ST/AS-26 to -28).

Step 2

Pouring height, reinforcements and boxouts

After performing step 1, the pouring height is defined and marked. Then the reinforcements and boxouts, if required, are installed.

Step 3

Place the inside formwork and tie the outside and inside formwork

The inside formwork is placed after the outside formwork. Then the inside and outside formwork are tied firmly with tie rods and articulated flange nuts.

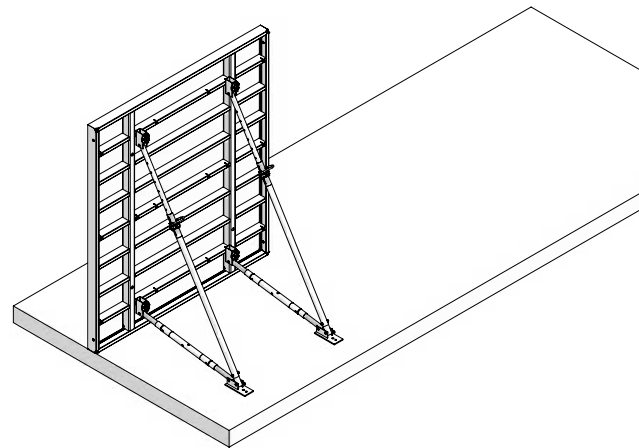

Fig. 5.1

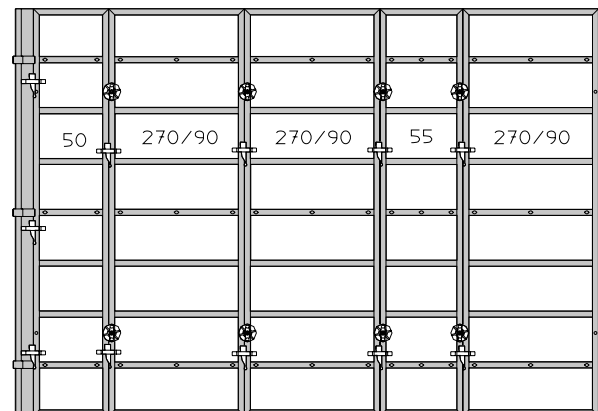

Fig. 5.2

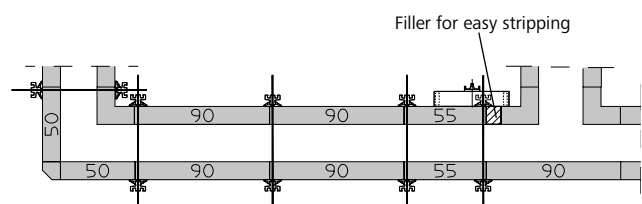

Fig. 5.3

Formwork assembly and stripping

Working scaffold

The plug-in walkway bracket (the figures show the BKB) is used to support the working scaffold. The maximum bracket spacing for a load of 150 kg/m² (platform group 2) is 250 cm as defined in DIN 4420. The planking must be at least 4.5 cm thick.

The planking and walkway bracket can be firmly connected. Do not install any planks before securing the formwork with push-pull props or before tying the inside and the outside formwork.

Do not forget to attach a side railing to the working scaffold.

Pouring concrete

Once you have placed, tied, braced and closed the formwork, you can start pouring concrete. When doing so, observe the permissible rate of placing taking the setting behaviour and the consistency of the cement into account (see page ST/AS-14).

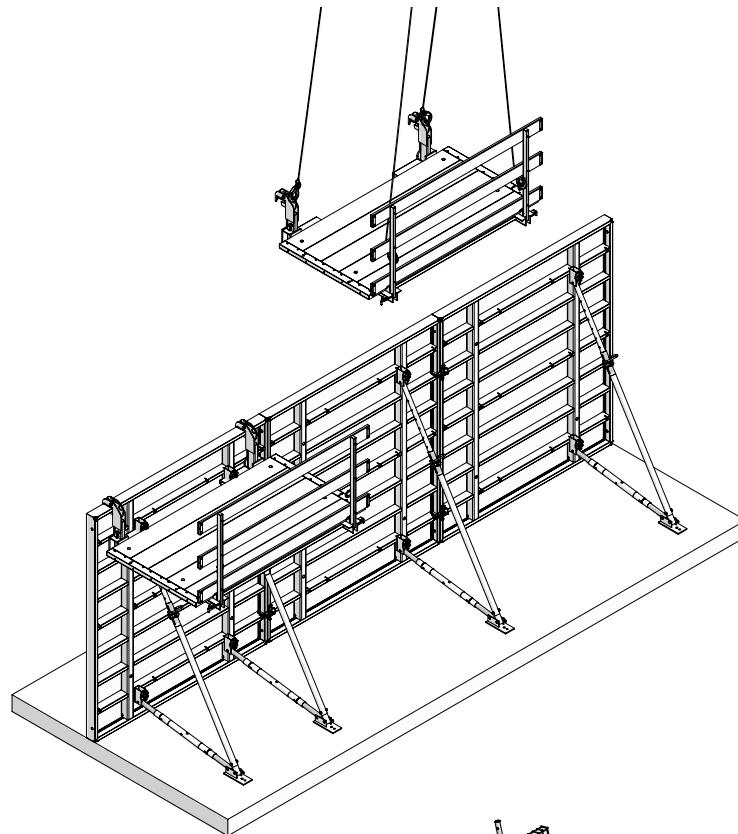

Fig. 6.1

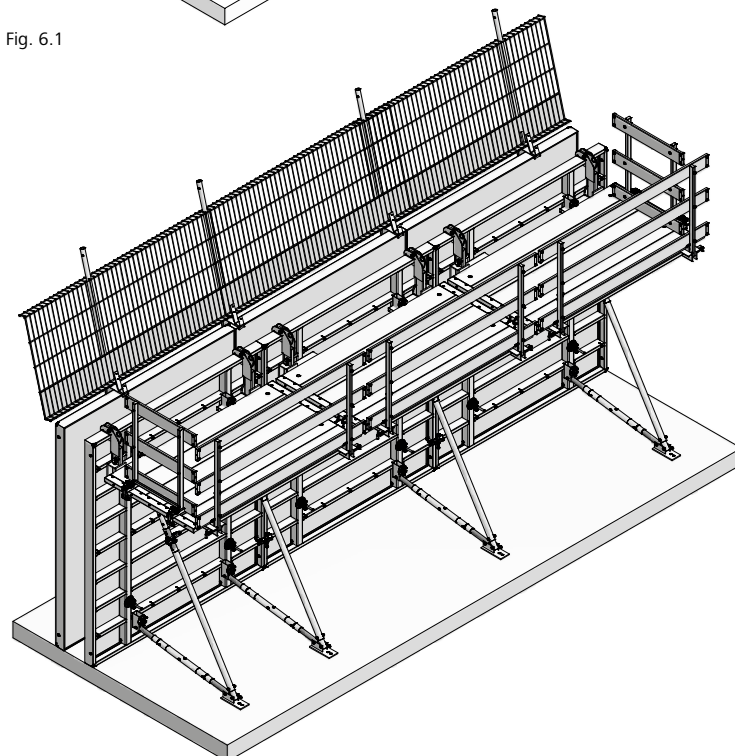

Fig. 6.2

Double-sided formwork with bracing and a working scaffold attached to the outside formwork

Formwork assembly and stripping

Stripping

Do not start stripping before the concrete has set to the point where it can no longer deform. It is best to start stripping at the stop ends or at a short corner. Start stripping with the inside formwork. Stripping of both the outside and inside formwork is performed as follows:

1. Remove the working scaffold.
2. Remove the articulated flange nuts and tie rods section by section. Make sure the unbraced formwork is immediately secured to prevent it falling over or strip it immediately.
3. On the formwork panels or large panel units the assembly locks are removed at the joints, and the panels or panel units are then lifted out by hand or by crane. Before transporting by crane, the formwork must be detached from the concrete!
4. Clean the facing and remove any concrete. Before the next use, spray the facing with the release agent MevaTrenn pro (for alkus facings). The release agent must not be stored in galvanized containers. Observe the operating instructions for the alkus facing.

Note

The release agent must not be stored in galvanized containers.

Please note

When stripping manually, detach and disassemble the working scaffold and the brace frames before stripping the panels.

When transporting large panel units with a crane, the working scaffold and wall braces are moved together with the panel units. While vertical, all components are cleaned and sprayed with release agent before being lifted together to the next cycle (see pages ST/AS-54 to -61).

If there is no further use for the panel units, the working scaffold and wall braces are detached and disassembled in a horizontal position, and cleaned and stacked for transport.

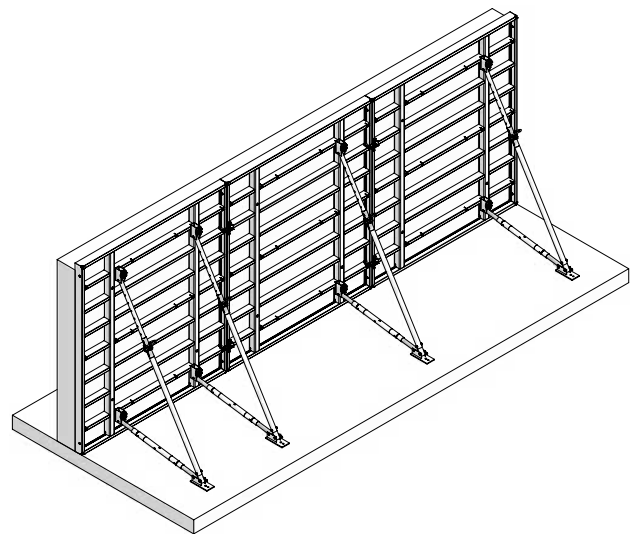

Fig. 7.1

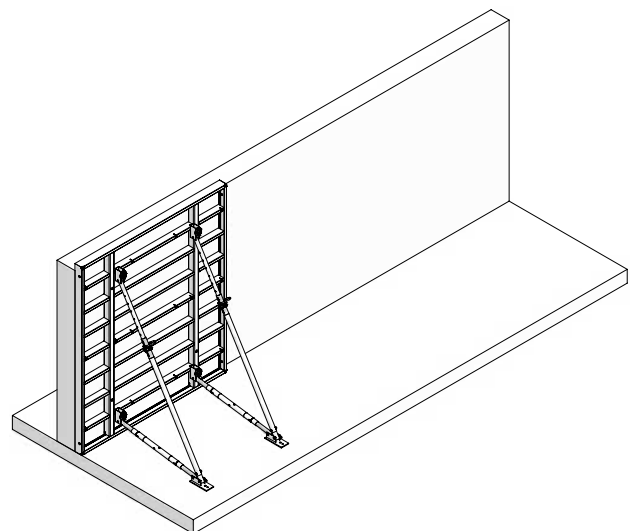

Fig. 7.2

Wall Formwork

The StarTec panel

Fig. 8.2
Tie hole with conical anchor sleeve (see page ST/AS-13).

Fig. 8.3
Panel connection with the AS assembly lock (see page ST/AS-12).

Fig. 8.4
Cross stiffener made of sturdy closed steel profile.

Fig. 8.5
Quick and secure attachment of accessories using welded-in DW 15 threaded nuts (see page ST/AS-16).

Fig. 8.6
Transport hole to attach the crane sling 40, allowing for fast loading and unloading of panel stacks or moving them at ground or slab level (see page ST/AS-72).

Fig. 8.7
The steel frames are made of closed hollow profiles with welded-in mitred joints. The profiles are provided with a groove and edge protection. Panels with a width of 135, 240 and 270 cm are equipped with four bump notches that are welded in diagonally, allowing exact panel positioning without a hammer.

Note
For a list of the all available panels including their designations and reference numbers refer to the Product List.

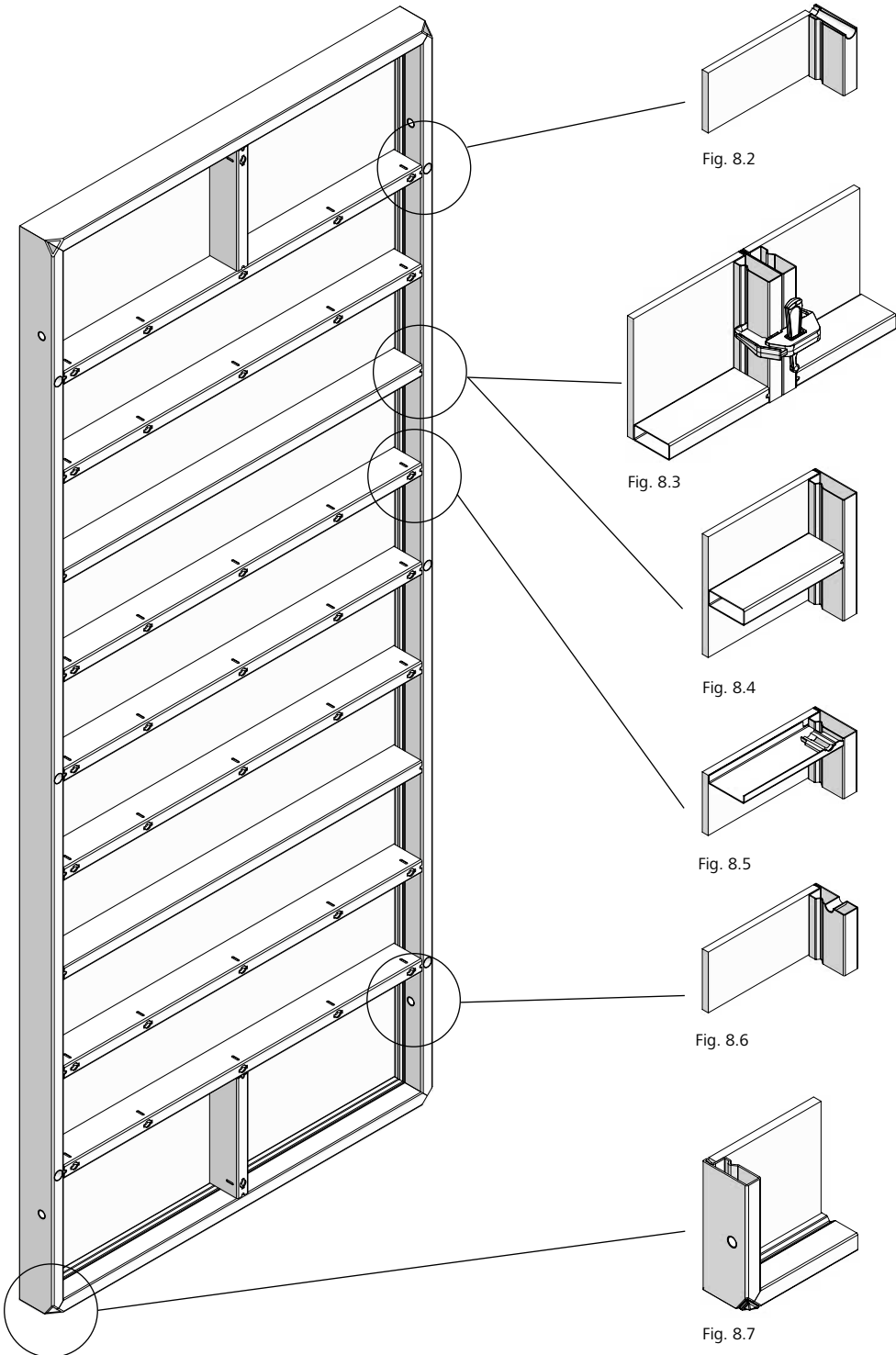

Fig. 8.1 StarTec 330/135

The StarTec panel

Large-size panels StarTec 330/270 and 270/240

These panels are ideally suited for vertical and horizontal use. Due to the internal tie holes only six tie rods are required for the 330/270 panel (Fig. 9.1) and for the 270/240 panel (Fig. 9.2) only four.

The panels can be connected to existing walls without alignment rails or fillers. They can overlap by up to 50 cm (see page ST/AS-43).

When horizontal panels are used for height extension, an even joint pattern with continuous vertical joints is assured if all top panels and height-extended panels have the same standard height.

Vertical and horizontal panels can be combined freely (Fig. 9.3).

Panels with a width of 135, 240 and 270 cm are equipped with four bump notches that are welded in diagonally, allowing exact panel positioning without a hammer (ST/AS-8.7).

Observe the transport guidelines (see page ST/AS-74).

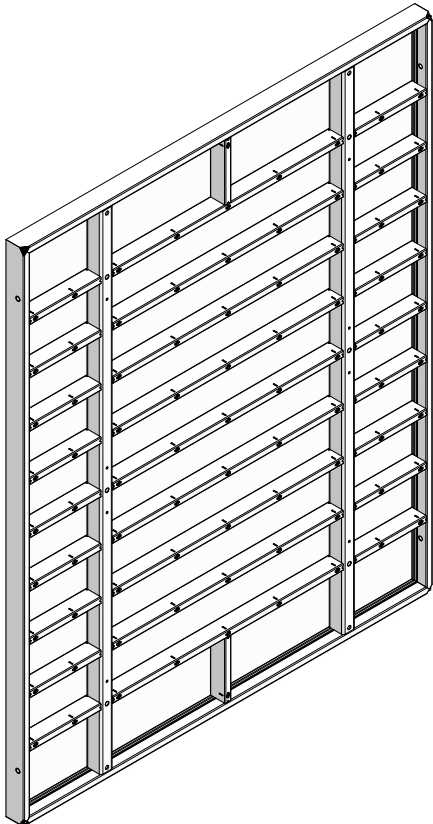

Fig. 9.1 StarTec 330/270

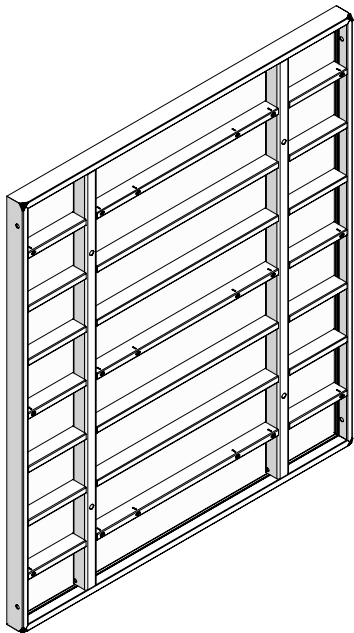

Fig. 9.2 StarTec 270/240

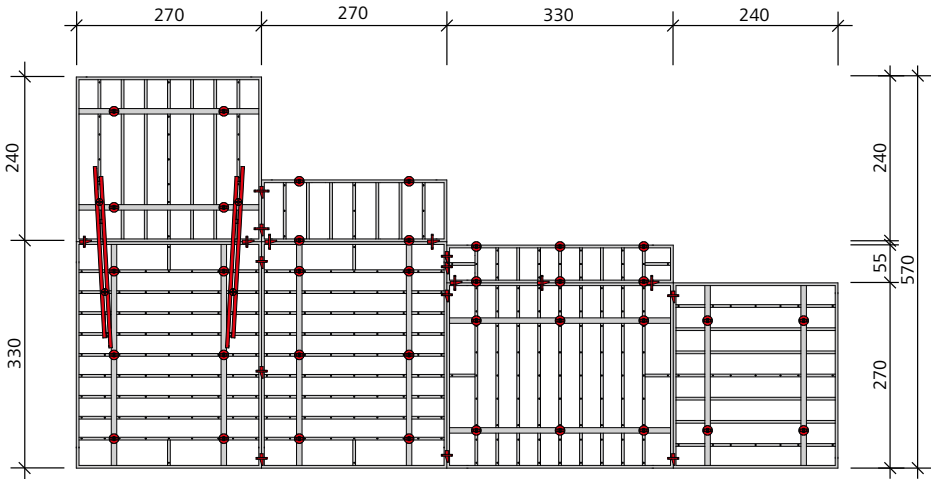

Fig. 9.3

Description	Ref. No.
StarTec AL 20 330/270	21-217-01
StarTec AL 20 270/240	21-200-03

The AluStar panel

Fig. 10.2
Tie hole with conical anchor sleeve (see page ST/AS-13)

Fig. 10.3
Panel connection with the AS assembly lock (see page ST/AS-12).

Fig. 10.4
Cross stiffener made of closed, robust and easy-to-handle aluminium profile.

Fig. 10.5
Quick and secure attachment of accessories using welded-in DW 15 threaded nuts (see page ST/AS-16).

Fig. 10.6
The aluminium frames are made of closed two-chamber hollow profiles with welded-in mitred joints. The profiles are provided with a groove and edge protection. Panels with a width of 90, 75 and 55 cm are equipped with four bump notches that are welded in diagonally, allowing exact panel positioning without a hammer.

Note
For a list of the all available panels including their designations and reference numbers refer to the Product List.

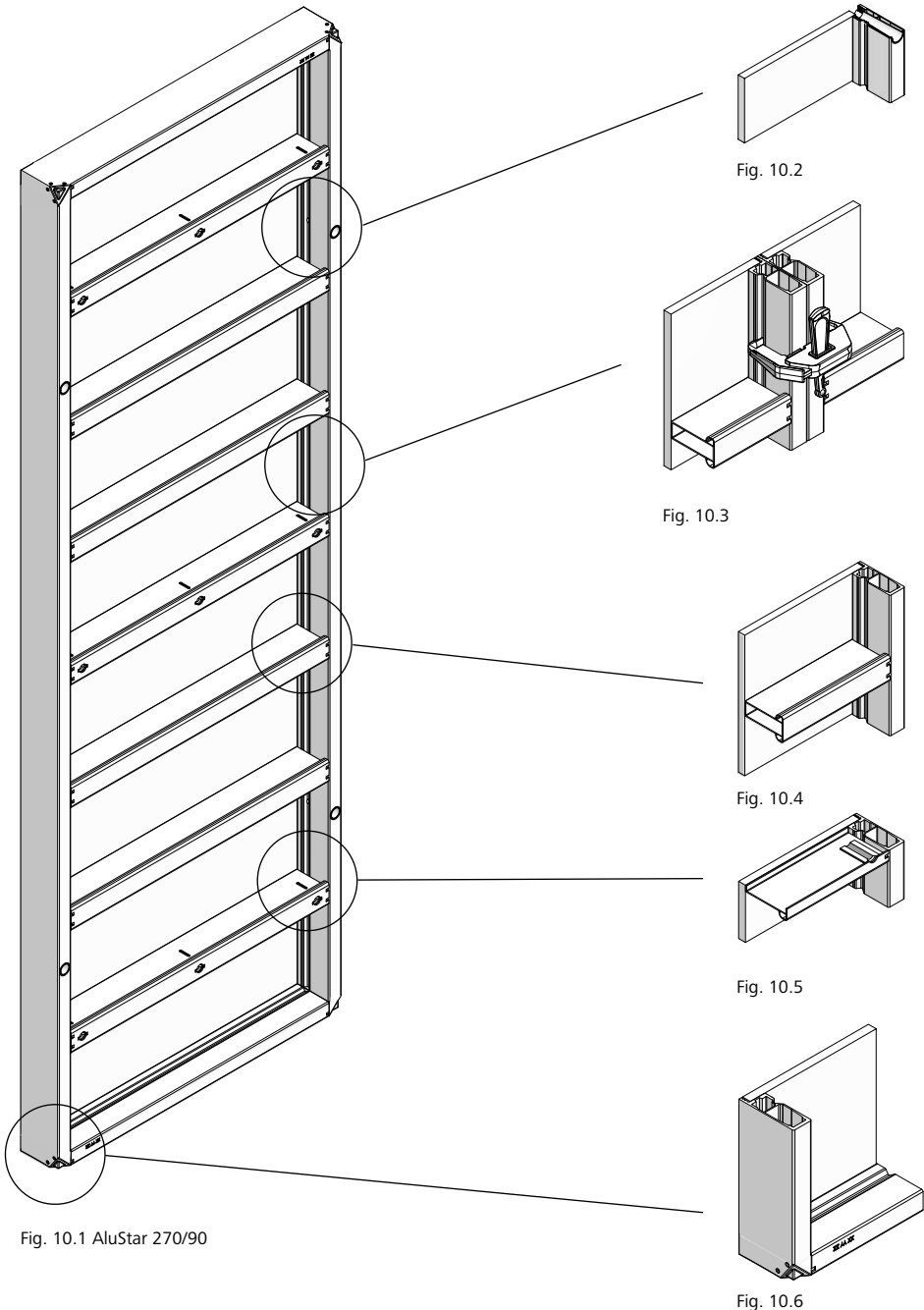

The alkus all-plastic facing

The tried-and-tested polypropylene and aluminium composite facing (Fig. 11.3) has all the positive properties of plywood plus important advantages: longer lifespan, greater load-bearing capacity, better nail-holding ability, fewer and easier repairs, 100% recyclability.

Besides the obvious advantages such as considerably reduced cleaning effort, minimum consumption of release agent and an excellent, uniform concrete finish, alkus offers substantial ecological benefits.

Substituting plastic for wood saves valuable timber resources. Also, alkus avoids the release of highly toxic dioxin that is released when burning plywood bonded with phenolic resin.

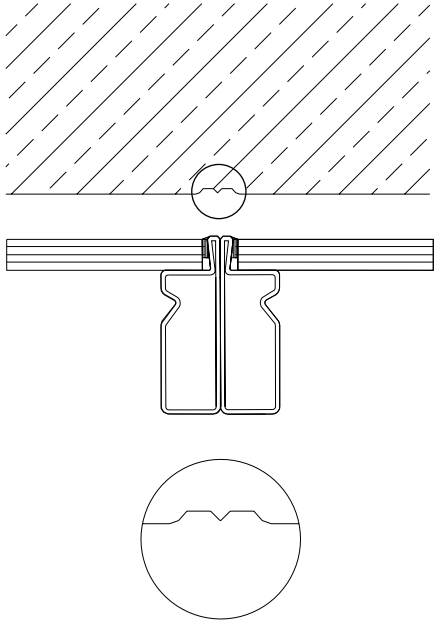

Fig. 11.1 Frame profile with plywood facing: Negative imprint in the concrete when using panels with a conventional plywood facing

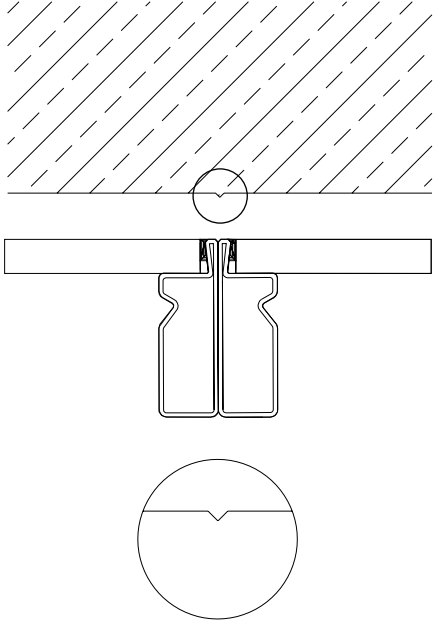

Fig. 11.2 Frame profile with alkus facing: Smooth and even concrete surface as there are no projecting profiles

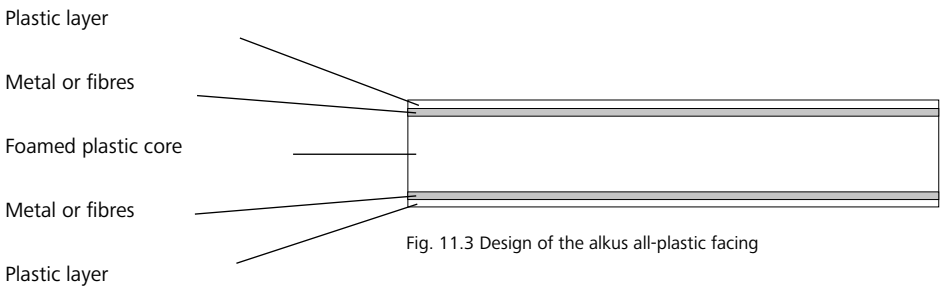

Fig. 11.3 Design of the alkus all-plastic facing

Wall Formwork

Panel connection

Fast and efficient connection of the panels is accomplished with the AS assembly lock (Fig. 12.1) whether the panels are assembled side by side or on top of each other (height-extended). The assembly lock can be attached at any position on the panel joint between the cross stiffeners. Since it weighs only 2 kg, it can be easily attached with only one hand.

Its 5-point contact (Figures 8.2 and 12.3) draws the panels together and aligns them. Secure connection and perfect alignment are achieved with only a few hammer blows. The assembly lock locks into a fail-safe position immediately and automatically.

Panels up to a height of 270 cm are connected with two assembly locks and panels with a height of 330 cm are connected with three assembly locks.

When pouring walls in SB3 quality (German architectural concrete class for immaculate architectural concrete surfaces), the use of an additional assembly lock is recommended to connect panels that are 270 cm high or higher.

Horizontal panel connections generally require two assembly locks.

For the number of assembly locks required for outside corners and columns refer to pages ST/AS-26 to 30 and ST/AS-62 and -63.

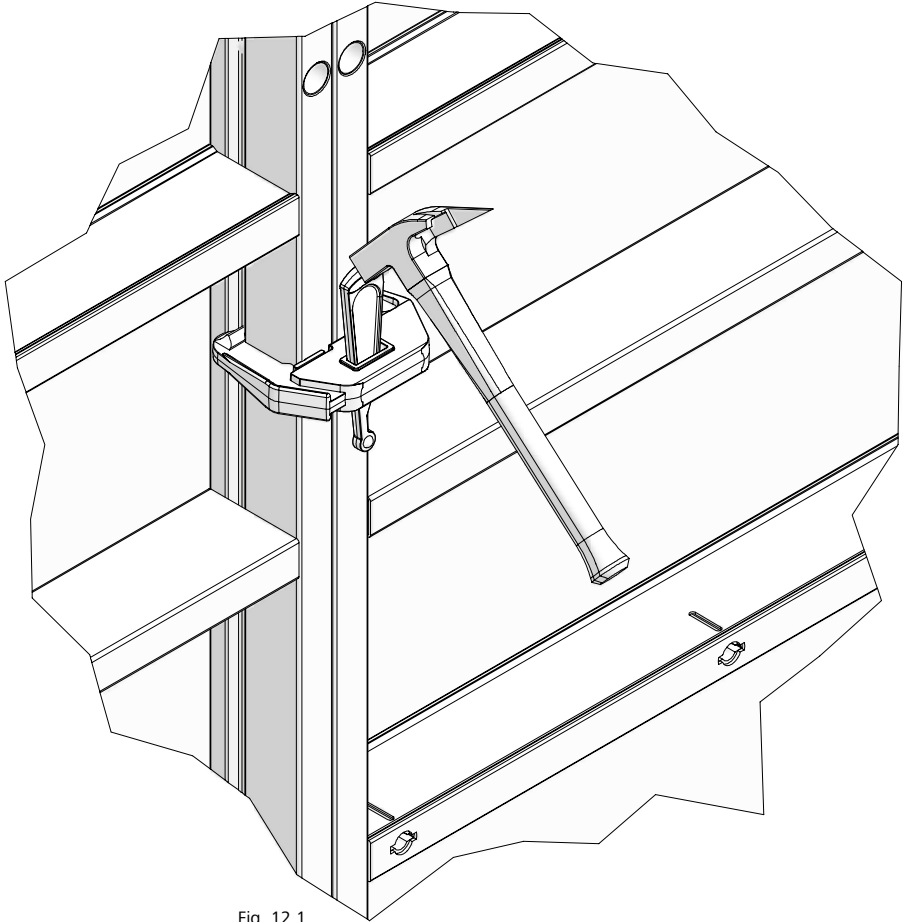



Fig. 12.1

 = 5-point contact

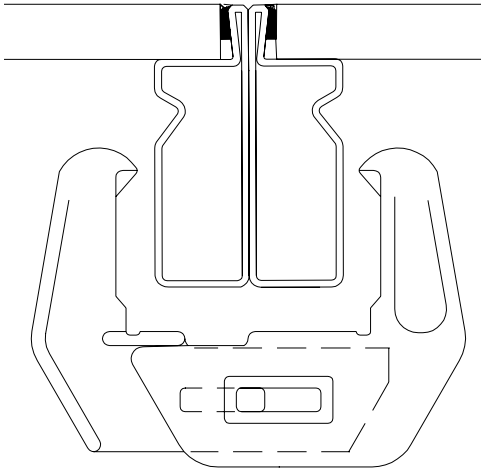

Fig. 12.2

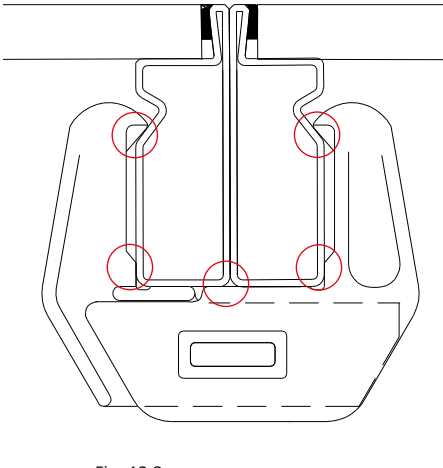

Fig. 12.3

Description	Ref. No.
AS assembly lock	29-205-00

Placing of ties

The conical anchor sleeve for tie rods DW 15 is welded to the panel frame (Figures 13.1 and 13.2).

The ST/AS formwork can be inclined up to 4 cm/m. Inclined formwork requires articulated flange nuts and must be secured against uplift.

The articulated flange nut 15/120 must be used for the AluStar formwork. Its revolving plate and nut prevent the panel being damaged. Use a size 27 spanner (Fig. 13.3) or a hammer (Fig. 13.4) to tighten and release the articulated flange nut 15/120.

When connecting panels with different widths, always anchor them through the wider panel (Fig. 13.5).

All usable tie holes must be used for tying. Non-usable tie holes must be closed with plug D20.

Panels can also be tied outside the panel using a Uni-tie claw (Fig. 13.6).

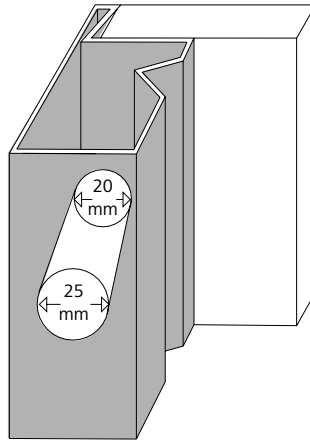

Fig. 13.1 StarTec

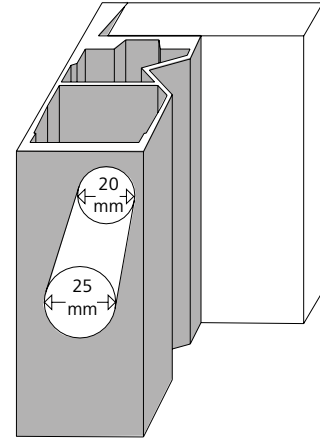

Fig. 13.2 AluStar

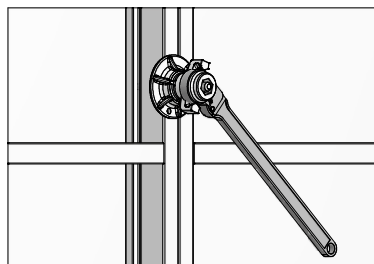

Fig. 13.3

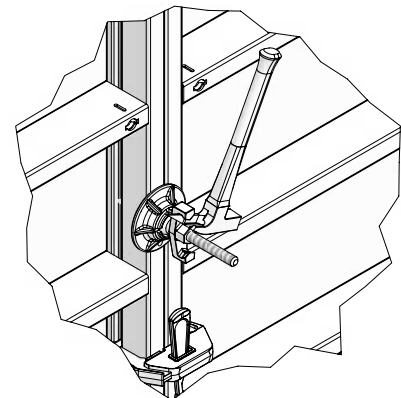

Fig. 13.4

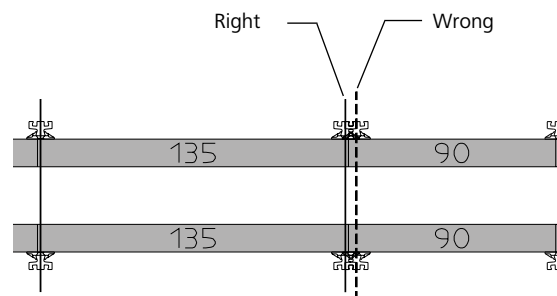

Fig. 13.5

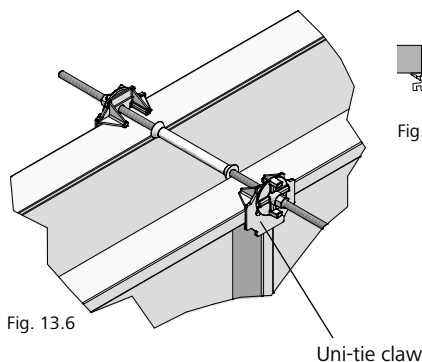

Fig. 13.6

Description	Ref. No.
Tie rod DW 15/90	29-900-80
Flange nut 100	29-900-20
Articulated flange nut 15/120	29-900-10
Plug D20	29-902-63
Uni-tie claw	29-901-41
Spanner size 27	29-800-10

Rules for concrete pouring and rate of placing

The maximum permissible fresh-concrete pressure for StarTec/AluStar is **60 kN/m²**.

Rules for concrete pouring

→ The rate of placing must not be taken into consideration for wall heights up to 2.40 m.

→ For the rate of placing of walls higher than 2.40 m refer to Table 14.1.

→ According to DIN 4235, concrete should be placed in layers whose thickness can vary from 0.50 m bis 1.00 m.

→ Concrete must not be placed above heights of 1.50 m (or higher) in free fall.

→ When vibrating the concrete, which is done layer by layer, the vibrator must not penetrate more than 0.50 m into the layer below.

→ A final vibrating step over the overall concrete height is not recommended. It does not provide any advantage, since concrete that has been vibrated once cannot be compacted further. This may result in water bubbles (shrinkage cavities) on the concrete surface.

Rate of placing

The permissible rate of placing can be precisely determined according to DIN 18218:2010-01 by referring to Table 14.1 or using MEVA's online calculation programme available on the MEVA website. This and other aids are available at www.meva.net.

Note that you cannot use the table unless you know the end of setting of the concrete, t_e . This value can be determined on-site using MEVA's ultrasonic SolidCheck measuring device or knead-bag tests as described in DIN 18218:2010-01. Or simply ask the concrete supplier for the concrete's end of setting.

Maximum rate of placing v_b (depending on the concrete's consistency and end of setting t_e)* in m/h					
StarTec/AluStar (60 kN/m ²)		$t_e = 5$ h	$t_e = 7$ h	$t_e = 10$ h	$t_e = 15$ h
Consistency range	F3	3.00	2.43	1.81	1.14
	F4	2.53	1.76	1.08	0.47
	F5	1.17	0.83	0.58	0.39
	F6	0.92	0.66	0.46	0.31
	SCC	1.06	0.76	0.53	0.35

Table 14.1

* According to DIN 18218:2010-01 (fresh-concrete pressure on vertical formwork)

t_e = End of setting of the concrete

v_b = Maximum rate of placing

Specific values of DW 15 tie rods

DW tie rod	15
d_1 (mm)	15
d_2 (mm)	17
Nominal cross section (mm ²)	177
Permissible working load according to DIN 18216 (kN)	90
Tie rod elongation when using the permissible working load (mm/m)	2.5

Table 14.2

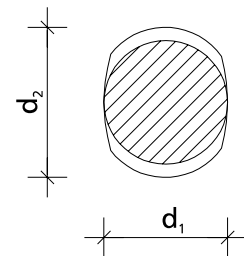

Flatness of surface

The permissible deflection of formwork parts is defined in DIN 18202 (flatness tolerances), Table 3, lines 5 to 7 (Table 15.1). Here, the maximum permissible deflection is defined in relation to the distance between the measuring points. The permissible fresh-concrete pressure that is in line with the flatness tolerances as defined in DIN 18202, Table 3, line 6 is 60 kN/m² (see page ST/AS-14).

DIN 18202, Table 3

Column	1	2	3	4	5	6
		Distances as limiting values in mm for distances between measuring points in m				
Line	Reference	0.1	1*	4*	10*	15*
5	Unexposed walls and undersides of slabs	5	10	15	25	30
6	Exposed walls and undersides of slabs, e.g. plastered walls, panelling, suspended ceilings	3	5	10	20	25
7	Like line 6, but with stricter requirements	2	3	8	15	20

Table 15.1

* Intermediate values can be found in Fig. 15.2. Round up values found to full millimetres.

The measuring lath is placed on the highest protruding points of the surface and the deflection is measured at the deepest point in-between.

The distance between measuring points corresponds to the distance between the highest protruding points.

Flatness tolerances of walls and undersides of slabs

(according to DIN 18202, Table 3)

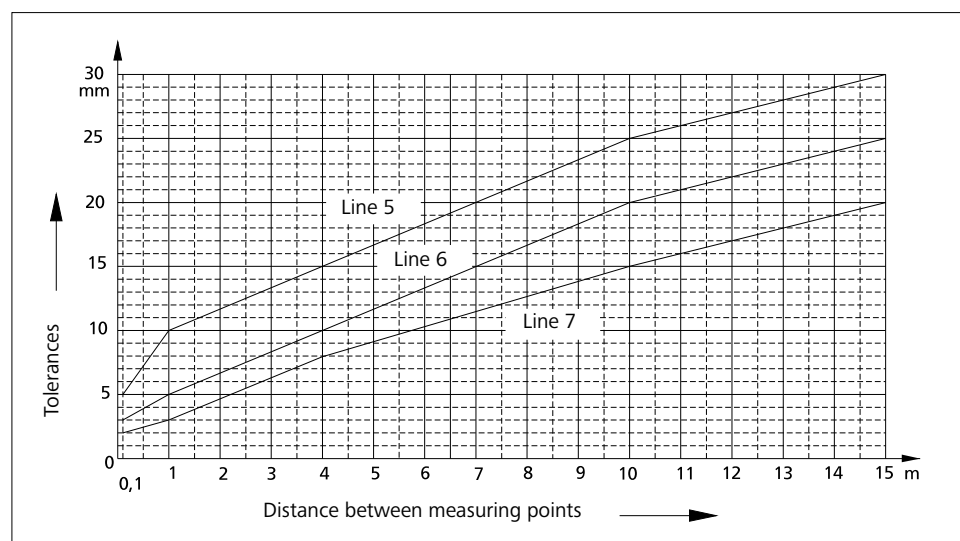

Fig. 15.2

Attachment of accessories

All panels are provided with multi-function profiles with welded-in Dywidag-threaded nuts (Figures 16.1 and 16.6). The difference between the multi-function profiles and the cross stiffeners is that the multi-function profiles allow accessories to be attached.

Walkway brackets are provided with integrated self-locking pins (Fig. 16.2) and are mounted on the multi-function profiles and secured with a flange screw 18.

Formwork is set vertically using push-pull props attached to the panel with formwork-prop connectors as shown in Fig. 16.3.

Alignment rails should be attached to the multi-function profiles with flange screws (Fig. 16.4) in order to

- stabilise ganged panels when lifting them by crane
- bridge problem areas
- brace and stabilise the fillers used to bridge gaps between the panels

The tie rod holder can be attached to the multi-function profile of the vertical or horizontal panel. It can hold up to two DW tie rods with articulated flange nuts (Fig. 16.5).

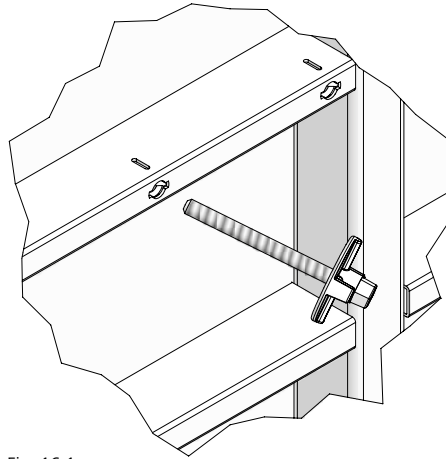

Fig. 16.1

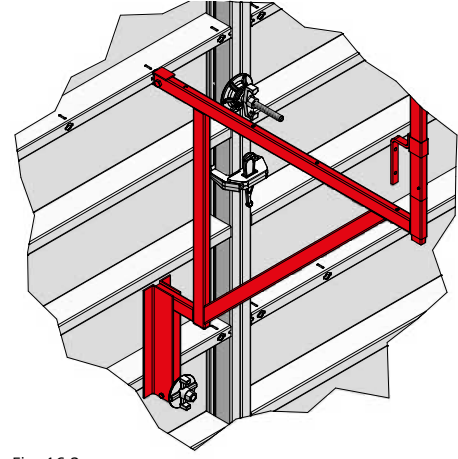

Fig. 16.2

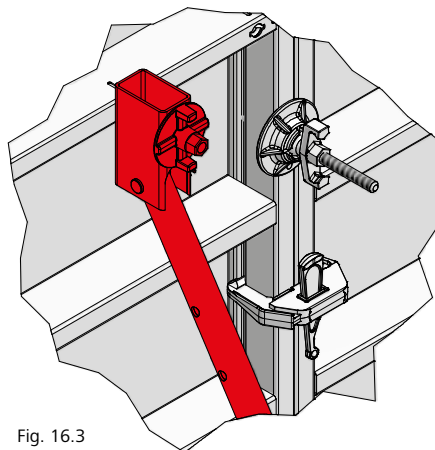

Fig. 16.3

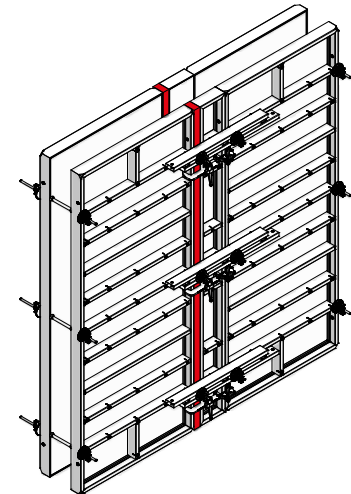

Fig. 16.4

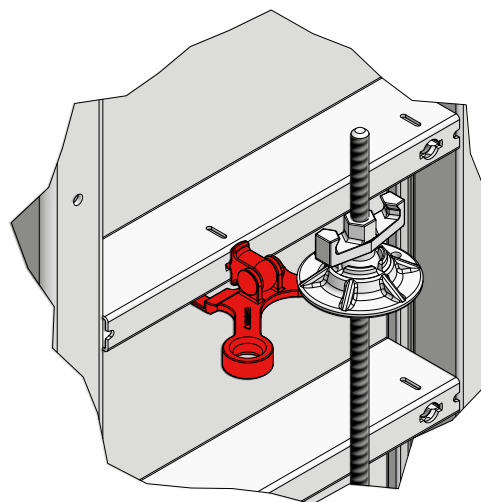

Fig. 16.5

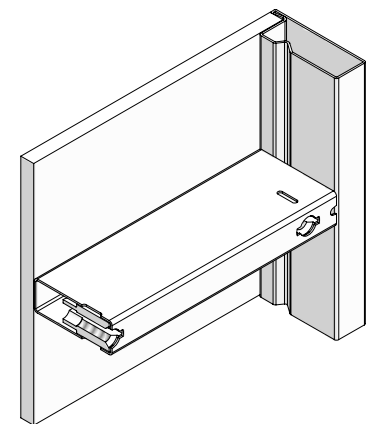

Fig. 16.6

Description	Ref. No.
Tie rod fixture Ø35.....	29-927-05

Wall Formwork

Wall braces

A push-pull prop or the brace frame 250 with formwork-prop connector is attached to the panel's multi-function profile with flange screw 18 (pages ST/AS-16 and -18).

The brace frame 250 is made up of the push-pull prop R 250, the brace SRL 120, two formwork-prop connectors and the double-jointed foot plate.

If push-pull props or brace frames are only used to align the formwork, we recommend a maximum spacing of 4.00 m. In order to withstand wind loads, refer to Table 17.1. For further applications contact MEVA.

Assumptions for Table 17.1

- Wind loads according to DIN EN 1991-1-4
- Wind zone 2, inland (mixed profile between terrain categories II and III)
- Impact pressure $q_p = 0.65 \text{ kN/m}^2$ (Table 17.2)
- Pressure coefficient used $c_p = 1.8$
- Exposure time factor $\psi = 0.7$
- Wind pressure $w = q_p \cdot c_p \cdot \psi$
- Formwork on upper edge of terrain
- Values are characteristic values

Wall braces	Formwork height h (m)						
	2.25	2.40	2.70	3.15	3.30	3.60	3.75
Push-pull prop	R250+ SRL120	R250+ SRL120	R250+ SRL120	R250+ SRL120	R250+ SRL120	R460+ SRL170	R460+ SRL170
Permissible influence width e (m)	6.30	3.80	5.35	4.21	3.77	4.04	3.78
Prevailing brace load F_1 (kN)	6.05	4.29	5.99	4.88	4.56	6.06	6.46
Prevailing push-pull prop load F_2 (kN)	11.28	7.22	11.77	12.04	11.50	11.76	10.62
Lifting force V_{Wind} (kN/m)	1.73	2.14	2.08	2.64	2.89	2.68	2.83
Prevailing dowel force V_{dowel} (kN)	14.24	12.58	14.18	14.48	14.78	14.14	14.25
Prevailing dowel force H_{dowel} (kN)	11.59	7.49	11.82	10.86	10.18	11.92	11.60
a (m)*	0.30	0.58	0.337	0.60	0.735	0.30	0.337
b (m)**	1.15	1.08	1.39	1.50	1.50	1.93	1.99

Wall braces	Formwork height h (m)						
	4.05	4.20	4.50	4.65	4.95	5.40	6.00
Push-pull prop	R460+ SRL170	R460+ SRL170	R460+ SRL170	R460+ SRL170	R460+ SRL170	R460+ R250	R460+ R250
Permissible influence width e (m)	3.57	3.31	3.10	2.72	2.48	2.28	2.00
Prevailing brace load F_1 (kN)	5.96	5.46	5.33	4.35	3.77	3.74	3.92
Prevailing push-pull prop load F_2 (kN)	11.85	11.95	12.21	12.13	12.60	12.70	11.88
Lifting force V_{Wind} (kN/m)	3.02	3.36	3.57	4.08	4.54	4.96	5.36
Prevailing dowel force V_{dowel} (kN)	14.17	14.30	14.32	14.69	14.81	14.84	14.04
Prevailing dowel force H_{dowel} (kN)	11.85	11.39	11.44	10.36	10.04	10.08	9.82
a (m)*	0.337	0.60	0.60	1.012	1.24	1.35	1.35
b (m)**	2.17	2.10	2.28	2.12	2.17	2.36	2.71

Table 17.1

* Upper pivot point a, distance measured between top edge of formwork and attachment point of the upper formwork-prop connector

** Distance to the foot plate b, measured from the rear edge of the formwork to the attachment of the foot plate

Wind impact pressure for buildings up to a height of 25 m:

Wind zone		Impact pressure q_p in kN/m^2 at a ground elevation within the limits		
		$h \leq 10 \text{ m}$	$10 \text{ m} < h \leq 18 \text{ m}$	$18 \text{ m} < h \leq 25 \text{ m}$
1	Inland	0.50	0.65	0.75
2	Inland	0.65	0.80	0.90
	Coast and island in Baltic Sea	0.85	1.00	1.10
3	Inland	0.80	0.95	1.10
	Coast and island in Baltic Sea	1.05	1.20	1.30
4	Inland	0.95	1.15	1.30
	Coast of North Sea and Baltic Sea and island in Baltic Sea	1.25	1.40	1.55
	Island in North Sea	1.40	-	-

Table 17.2

Description	Ref. No.
Braces SRL	
SRL 120	29-108-80
SRL 170	29-108-90
Push-pull props R	
R 160	29-109-40
R 250	29-109-60
R 460	29-109-80
R 630	29-109-85
Formwork-prop connector	29-804-85
Brace frame 250 with formwork-prop connector	29-109-20
Flange screw 18	29-401-10
Double-jointed foot plate	29-402-32

Wall Formwork

Wall braces

The brace is attached to the double-jointed foot plate (Fig. 18.2) using MEVA quick anchors or anchor bolt, for example.

The permissible influence width of the bracing (e) can be reduced at the edge of the formwork as shown in Fig. 18.3.

→ e = permissible influence width (see Table ST/AS-17.1)

The shoe plate 40 can be used to secure the StarTec/AluStar panel to the ground (Fig. 18.4). It can be secured using a MEVA quick anchor or an anchor bolt.

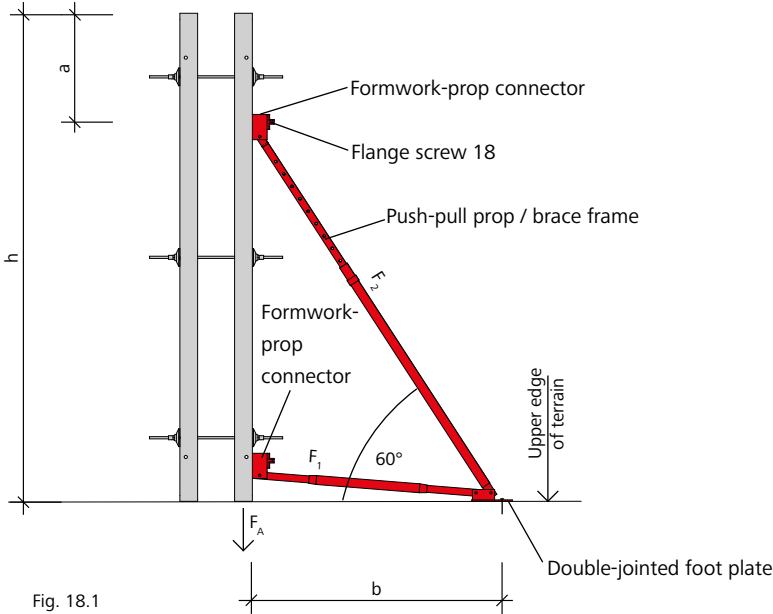

Fig. 18.1

Note:

A restraint mechanism is required when the lifting force $F_A = 1.5 \times V_{Wind} - 0.9 \times G \times h > 0$.
 G = weight per unit area of the formwork (including platforms)

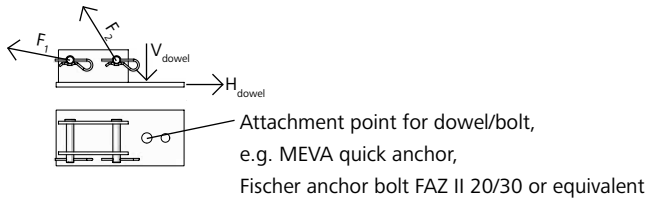

Fig. 18.2 Double-jointed foot plate

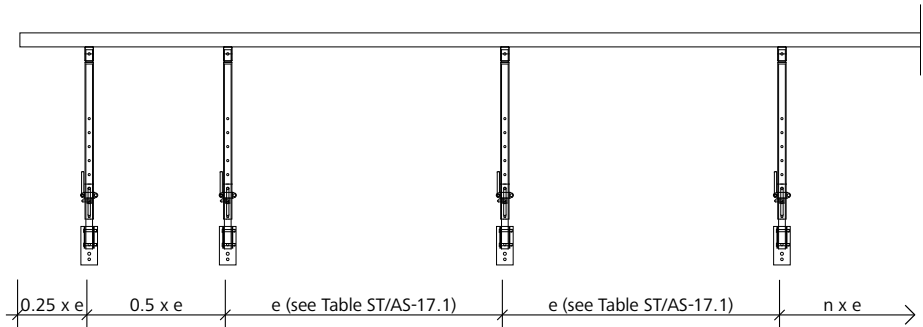

Fig. 18.3

Description	Ref. No.
Braces SRL	
SRL 120	29-108-80
SRL 170	29-108-90
Push-pull props R	
R 160	29-109-40
R 250	29-109-60
R 460	29-109-80
R 630	29-109-85
Formwork-prop connector	29-804-85
Brace frame 250 with formwork-prop connector	29-109-20
Flange screw 18	29-401-10
Double-jointed foot plate	29-402-32
Quick anchor	29-922-70
Shoe plate 40	23-311-92
Spiral anchor DW 15/100	29-921-10

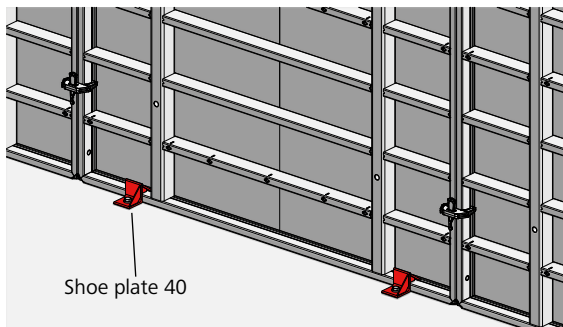

Fig. 18.4

Working scaffolds – Folding access platform BKB 125

Folding access platform BKB 125

The ready-made folding access platform BKB 125 with folding guardrailing provides safe access and a 125 cm wide working platform (Fig 19.2). It enables quick and safe installation of working scaffolds.

The 48 mm thick planks have a rough surface and a metal lining at the edges.

Its length of 235 cm allows the BKB 125/235 to be easily transported, as it fits crosswise on any truck. When stacked, it is only 17 cm high. The permissible load is 2 kN/m² (200 kg/m²).

The guardrailing can be set at an angle of 90° or 105° (Fig. 19.1). The BKB 125 side railing is mounted to the platform with two flange screws 18 (Fig. 19.5).

Attention

Do not crane formwork units when the working platform is attached to the formwork.

To relocate the individual platforms with a crane so that they are all at the same height, we recommend adjusting the length of the chains on the crane sling.

When using our products, the federal, state and local codes and regulations must be observed.

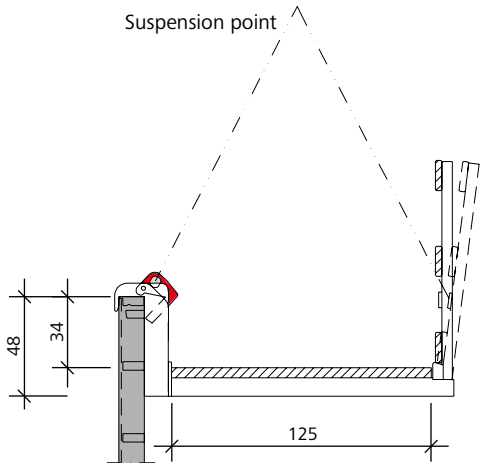

Fig. 19.1

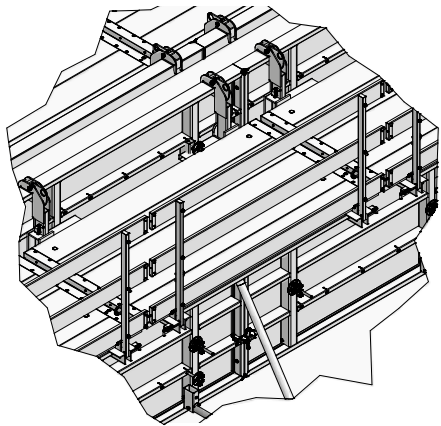

Fig. 19.2

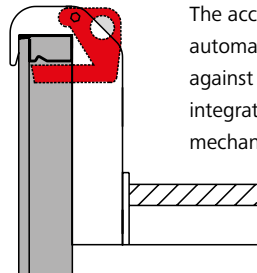

Fig. 19.3

The access platform is automatically secured against dislodging by the integrated self-locking mechanism.

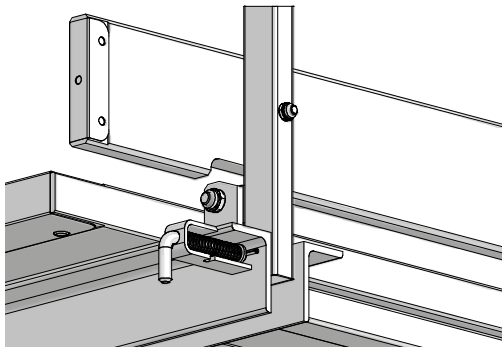

Fig. 19.4

Examples for corner configurations and length compensation

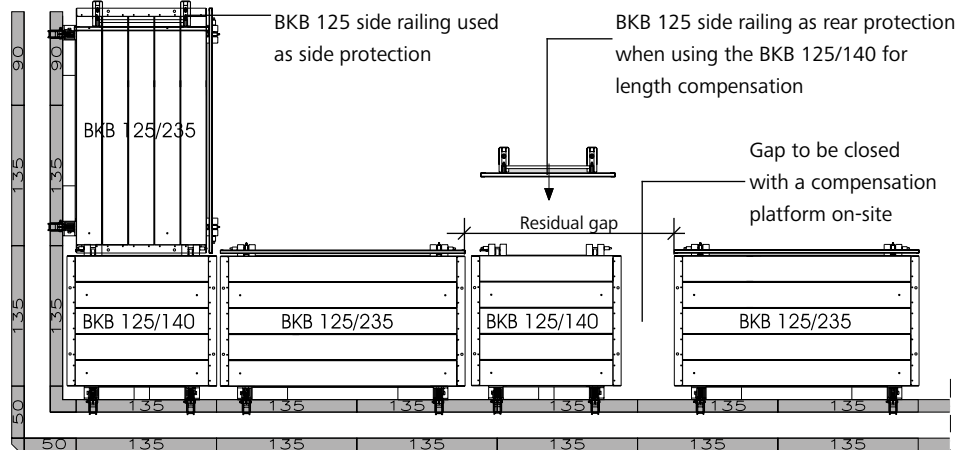

Fig. 19.5

Description	Ref. No.
Folding access platform	
BKB 125/140	29-417-00
BKB 125/235	29-417-10
BKB 125/300	29-417-20
Side railing BKB 125.....	29-417-30

Working scaffolds – Folding access platform BKB 125

When using the BKB folding access platform with 330 cm high StarTec panels, tying at the top needs to be done above the panels using Uni-tie claws rather than tying through the top tie holes (Figures 20.1 and 20.2).

Two Uni-tie claws, one DW 15 tie rod and two flange nuts 100 are required per tie connection (Fig. 20.3). We also recommend the use of a plastic tube. It serves as a spacer and protects the tie connection against contamination.

Unused tie holes must be closed with plug D20.

Note

MEVA's Securit safety system offers platforms, ladder access and other safety equipment for safe and efficient work at all heights. The Securit platforms are fully compatible with the StarTec wall formwork.

Refer to the SecuritBasic and ST Securit technical instruction manuals.

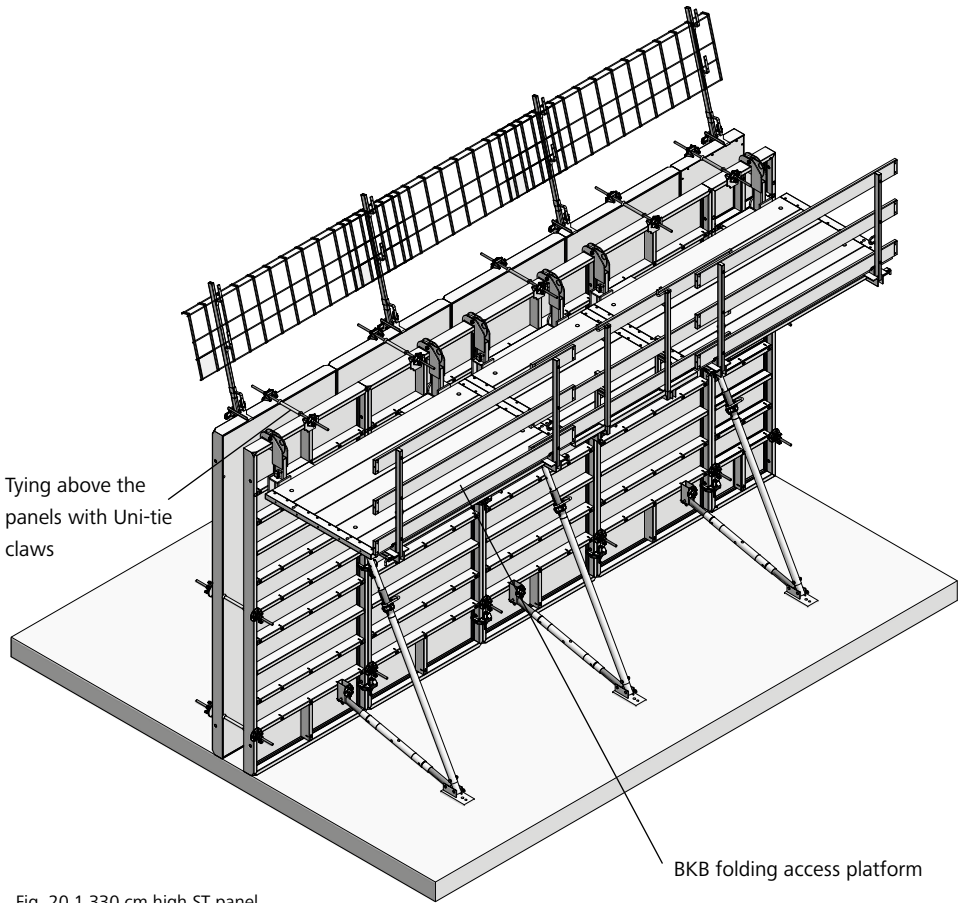

Fig. 20.1 330 cm high ST panel

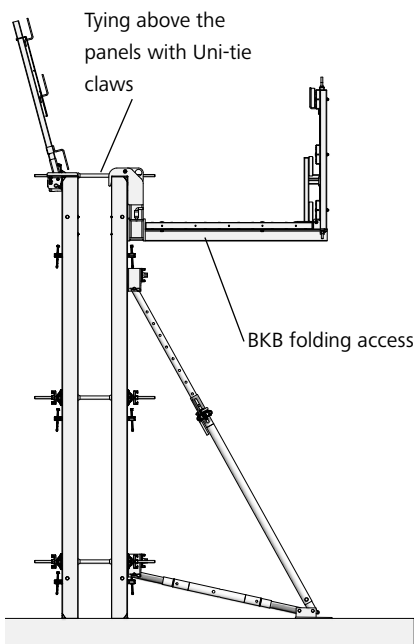

Fig. 20.2

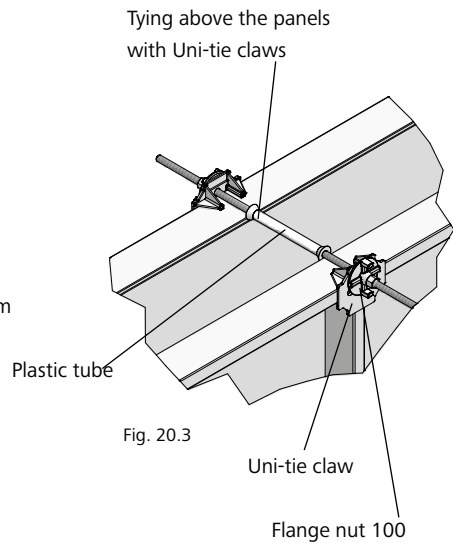

Fig. 20.3

Description	Ref. No.
Tie rod DW 15/90	29-900-80
Flange nut 100	29-900-20
Uni-tie claw	29-901-41
Plug D20.....	29-902-63

Working scaffolds / walkway brackets

Walkway bracket

The pluggable walkway bracket 90 (Fig. 21.2) is mounted to a multi-function profile. To insert the bracket, turn it by 45°, then turn it back to the vertical position and secure it with a flange screw 18 to the multi-function profile below. The planks can then be bolted to the brackets. Maximum bracket spacing for a load of 150 kg/m² (scaffold group 2): 2.50 m according to DIN 4420. The minimum thickness of the planks is 4.5 cm and their minimum width is 24 cm.

Guardrailing posts and side railing

The guardrailing posts and the side railing (Figures 21.3 to 21.5) are inserted into the walkway brackets. If the fall height exceeds 2.00 m, a side railing (Fig. 21.5) is required. Note that this regulation is valid for Germany.

Always observe the federal, state and local regulations of the country where the formwork is used.

The guardrailing post 48/120 UK can be used to allow scaffold tubes or safety meshes to be installed as a fall protection measure. These guardrailing posts are made of round tube with a diameter of Ø 48 mm. Swivel-joint couplers for the scaffold tubes are attached to the guardrailing posts. The round guardrailing posts are inserted into the walkway brackets with their rectangular adapters (Fig. 21.4).

Note
Minimum cross section of handrail and midrail:
For a post spacing of up to 2.00 m: 15 x 3 cm
For a post spacing of up to 3.00 m: 20 x 4 cm (Fig. 21.1).

Working scaffold according to DIN 4420, Part 1

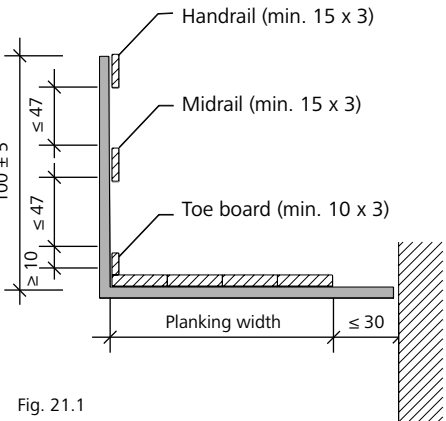

Fig. 21.1

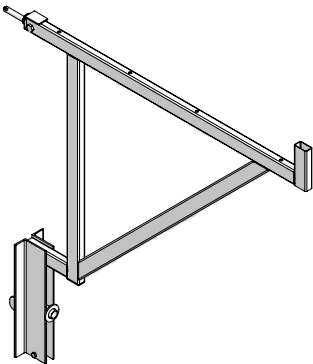

Fig. 21.2 Walkway bracket 90

Description	Ref. No.
Walkway bracket 90	29-106-00
Flange screw 18	29-401-10
Guardrailing post 100	29-106-75
Guardrailing post 140	29-106-85
Guardrailing post 48/120 UK	29-106-80
Side railing 90/100	29-108-20
Swivel-joint coupler 48/48	29-412-52
Scaffold tube 48/200	29-412-23
Scaffold tube 48/300	29-412-26
Scaffold tube 48/400	29-412-27
Scaffold tube 48/500	29-412-25
Scaffold tube 48/600	29-412-28

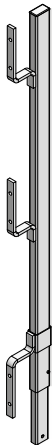

Fig. 21.3
Guardrailing post 100 or 140



Fig. 21.4
Guardrailing post 48/120 UK

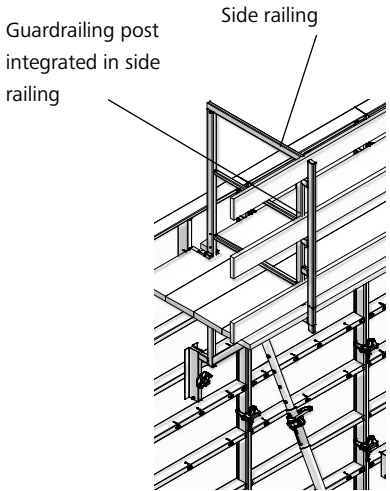

Fig. 21.5
Side railing

Working scaffold – Ladder fixture for wall formwork

The ladder fixture for wall formwork enables a ladder or an extension ladder to be firmly attached to the horizontal or vertical wall formwork panel and thus ensures safe access to the working scaffold, e.g. walkway bracket or BKB folding access platform.

The upper ladder fixture for wall formwork is attached to a multi-function nut of the formwork panel with the integrated flange screw. This is used to hook on the ladder. The integrated safety lever prevents the ladder lifting out accidentally.

The lower ladder fixture for wall formwork is attached to the bottom of the wall formwork panel with the integrated flange screw. It is used to secure the ladder.

Both the ladder and the extension ladder can be equipped with a safety cage.

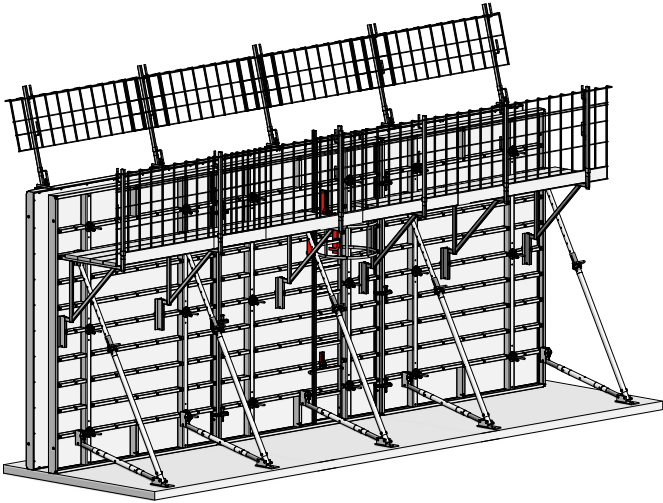

Fig. 22.1

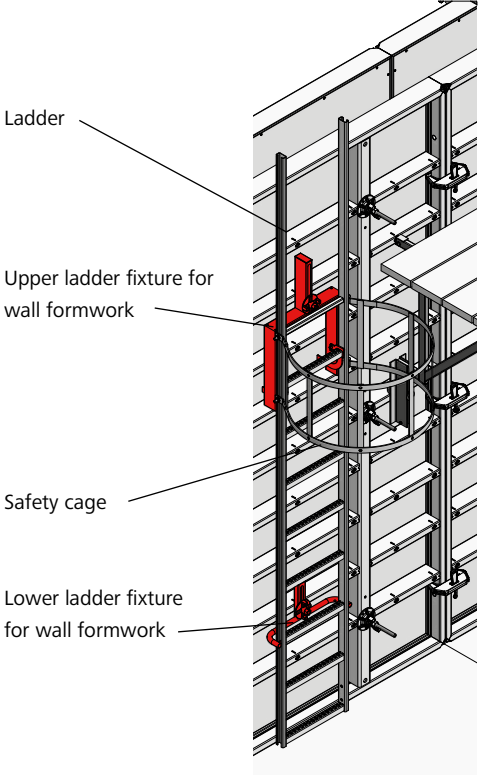

Fig. 22.3

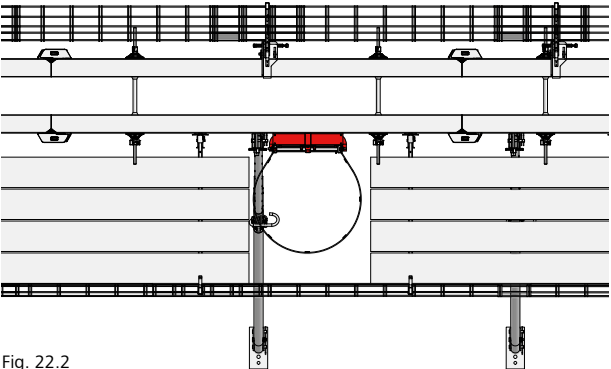

Fig. 22.2

Description	Ref. No.
Ladder fixture for wall formwork	
upper.....	29-416-82
lower.....	29-416-84
Ladder 348.....	29-414-50
Ladder 318.....	29-414-55
Ladder 243.....	29-416-50
Extension ladder 270.....	29-416-52
Extension ladder 210.....	29-414-60
Extension ladder 120.....	29-416-55
Extension ladder 90.....	29-416-60
Extension ladder 60.....	29-416-62
Ladder connector.....	29-414-70
Safety cage 210.....	29-414-85
Safety cage 85.....	29-414-90
Safety cage 40.....	29-416-90

Fall protection – Tilting bracket 40/60

An additional fall protection device on the opposite side of the working scaffolds, i.e. on the other side of the formwork, is required for heights above 2.00 m. Note that this regulation is valid for Germany. Make sure to observe the federal, state and local regulations of the country where the formwork is used.

The tilting bracket 40/60 (Fig. 23.1) is designed for the MEVA wall formwork systems Mammut XT, Mammut 350, Mammut, StarTec XT and StarTec/AluStar and is used to attach MEVA guardrailing posts to create a fall protection system.

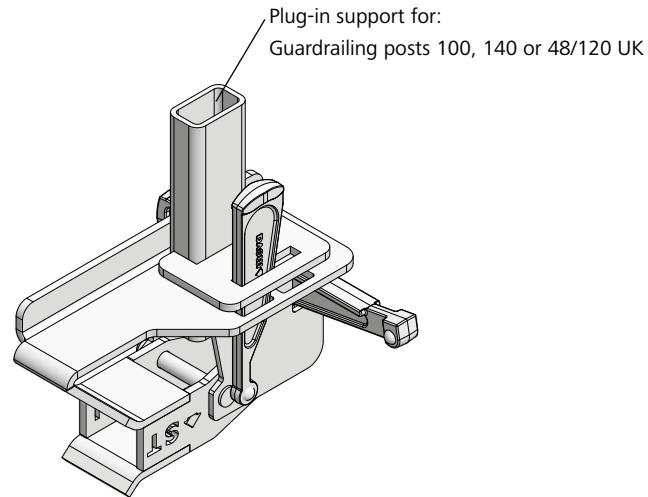

Fig. 23.1

It is attached to the panel's frame profile with the integrated wedge (Fig. 23.2).

MEVA guardrailing posts 100, 140 and 48/120 UK can be connected to the bracket.

The tilting bracket can be turned so that it is vertical to facilitate the installation of safety meshes or railing boards. It can also be tilted by 15° to create sufficient room for the concrete bucket (Fig. 23.2).

One guardrailing post per bracket must be ordered separately.

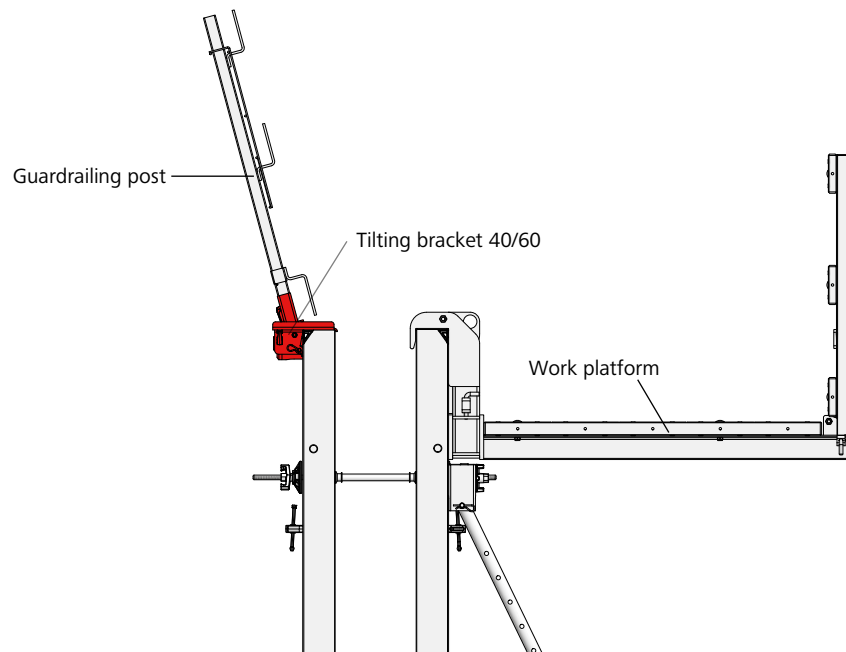

Fig. 23.2

Description	Ref. No.
Tilting bracket 40/60.....	29-920-82
Guardrailing post 100.....	29-106-75
Guardrailing post 140.....	29-106-85
Guardrailing post 48/120 UK ..	29-106-80

Wall Formwork

Crane hook

The permissible load of a AS crane hook (Fig. 24.1) is 15 kN (1.5 t).

Important

The load-bearing capacity of 15 kN (1.5 tons) may be reduced depending on whether the panels are lifted vertically or horizontally, whether the cross stiffeners are made of aluminium or steel and depending on the year of manufacture of the panels (see page ST/AS-54).

Handling

1. Open the safety lever as far as possible (Fig. 24.2).
2. Push the crane hook over the panel profile until the claw engages completely in the groove.
3. Release the safety lever and press it back to its start position so that the crane hook is locked completely (Fig. 24.3).

Attention

Always use two crane hooks, even when moving single panels. Always attach the crane hooks symmetrically to the centre of gravity.

The opening angle of the crane slings must not exceed 60° (Fig. 24.4).

When moving single horizontal panels, both crane hooks must be attached at the centre of gravity over the cross stiffeners of the profile. When moving several panels at once, make sure each crane hook is attached at a panel joint (Fig. 24.4). This prevents the crane hook slipping.

When to replace the crane hook

If the reference dimension exceeds 41 mm, the crane hook must be replaced immediately. This also applies if only one side of the hook exceeds this dimension (Fig. 24.5).

Safety check

Always check the crane hook before use. Do not overload the crane hook. Exceeding the permissible loading can result in excessive elongation and thus permanent deformation. A damaged crane hook is not capable of supporting the full load and its safe use can no longer be guaranteed.

Safety regulations

When using our products, the federal, state and local codes and regulations must be observed.

Also observe the operating instructions delivered with the crane hook.

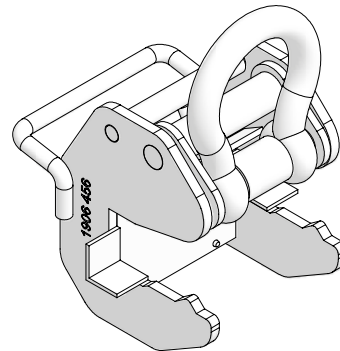

Fig. 24.1

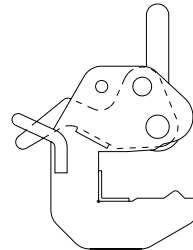

Fig. 24.2

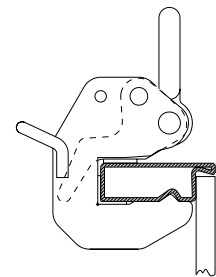

Fig. 24.3

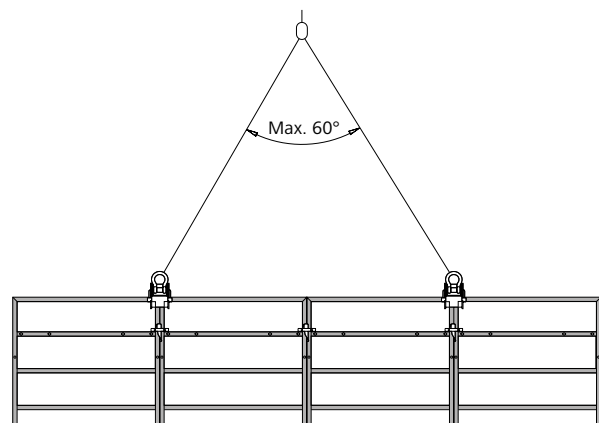

Fig. 24.4

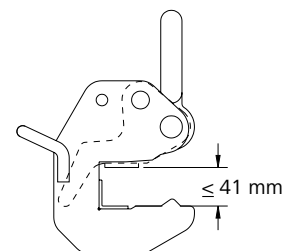

Fig. 24.5

Description	Ref. No.
AS crane hook	29-203-89

Wall Formwork

Inside corner 90°

The StarTec inside corner is galvanised and has an alkus all-plastic facing. The AluStar inside corner is made of aluminium with a high-quality cured powder coating.

Both inside corners have tie holes and, as is the case for a standard panel, require three assembly locks per joint for the height 330 cm (Fig. 25.1) and two assembly locks per joint up to a height of 270 cm (Fig. 25.3). Each corner side is 25 cm (Fig. 25.2).

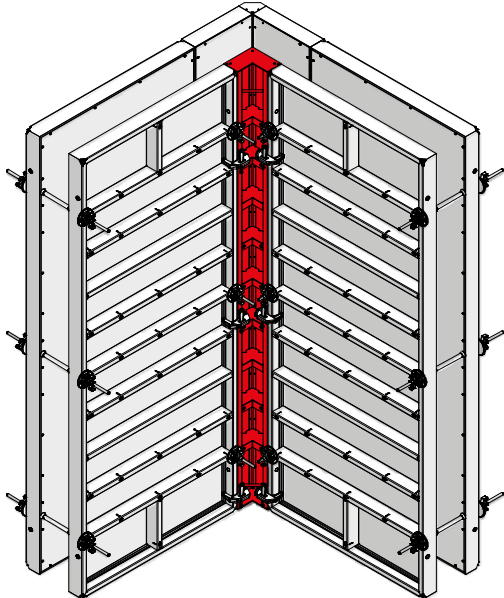

Fig. 25.1

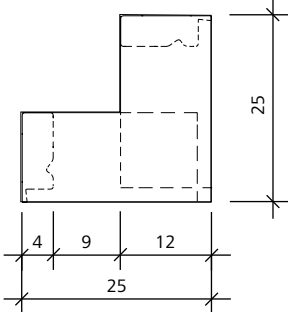

Fig. 25.2

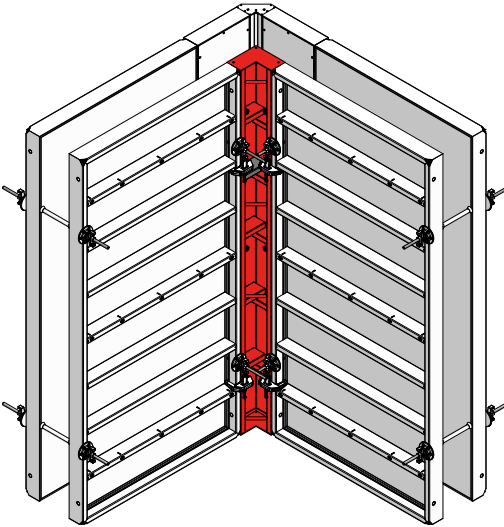

Fig. 25.3

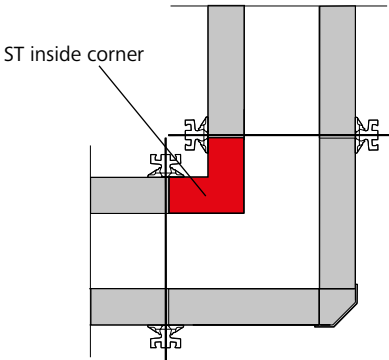

Fig. 25.4

Description	Ref. No.
StarTec AL IC 330/25	21-251-00
StarTec AL IC 270/25	21-251-05
StarTec AL IC 135/25	21-251-35
StarTec AL IC 90/25	21-251-65
AluStar AL IC 330/25	22-150-22
AluStar AL IC 270/25	22-150-24
AluStar AL IC 135/25	22-150-34
AluStar AL IC 135/25	22-150-44
AS/ST aluminium filler 330/5 ..	21-270-58
AS/ST aluminium filler 270/5 ..	21-270-60
AS/ST aluminium filler 135/5 ..	21-270-65
Uni-assembly lock 22	29-400-85
Uni-assembly lock 28	29-400-90
RS assembly lock	23-807-70

Wall Formwork

Outside corner 90°

The aluminium AS/ST outside corner with its high-quality cured powder coating (Figures 26.1 to 26.3) together with the StarTec or AluStar panels and the AS assembly lock results in a solid 90° outside corner solution.

For the number of AS assembly locks required for an outside corner (a) as well as for the next panel joint (b) refer to Table 26.3. For the assembly locks and alignment rails required for height-extended outside corners refer to page ST/AS-28).

The width of the panel adjoining the outside corner is calculated as follows: wall thickness (cm) + 25 cm (Fig. 26.4).

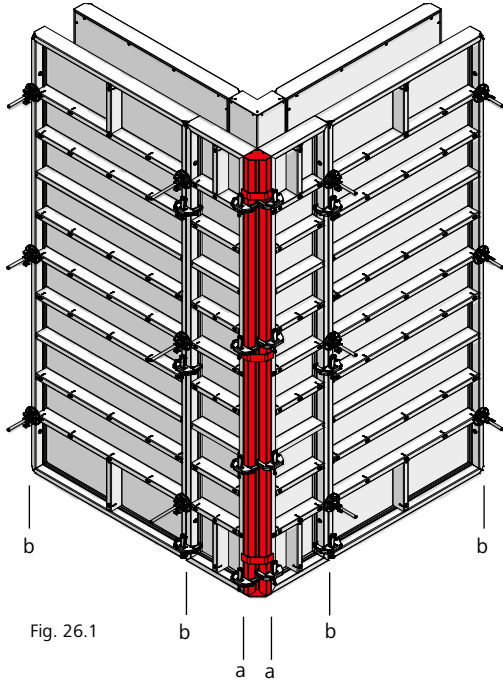

Fig. 26.1

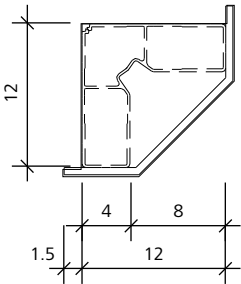

Fig. 26.2

Panel height (in cm)	Number of AS assembly locks	
	(a)	(b)
330	4	3
270	3	2
135	2	2
90	2	2

Table 26.3

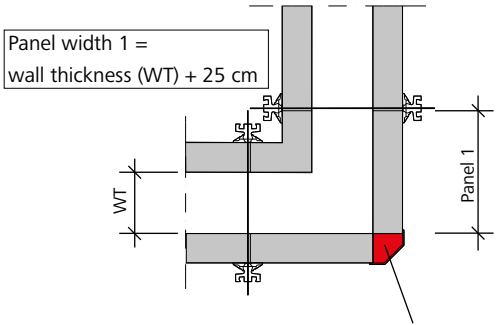

Fig. 26.4

AS/ST outside corner

Description	Ref. No.
AS/ST outside corner 330.....	22-140-10
AS/ST outside corner 270.....	22-140-20
AS/ST outside corner 135.....	22-140-30
AS/ST outside corner 90.....	22-140-40
AS/ST aluminium filler 270/5..	21-270-60
AS/ST aluminium filler 135/5..	21-270-65

Wall Formwork

90° outside corner with side lengths 10 cm and 5 cm

The aluminium outside corner with a high-quality cured powder coating and 10 cm and 5 cm side lengths on both sides as well as an integrated triangular fillet (Fig. 27.1) together with the StarTec or AluStar panels and the AS assembly lock result in a solid 90° outside corner solution.

For the number of AS assembly locks required for an outside corner (a) as well as for the next panel joint (b) refer to Table 27.2. For the assembly locks and alignment rails required for height-extended outside corners refer to page ST/AS-28.

The width of the panel adjoining the outside corner is calculated as follows:

- Outside corner 10 = Wall thickness (cm) +15
- Outside corner 5 = Wall thickness (cm) + 20 (Fig. 27.4).

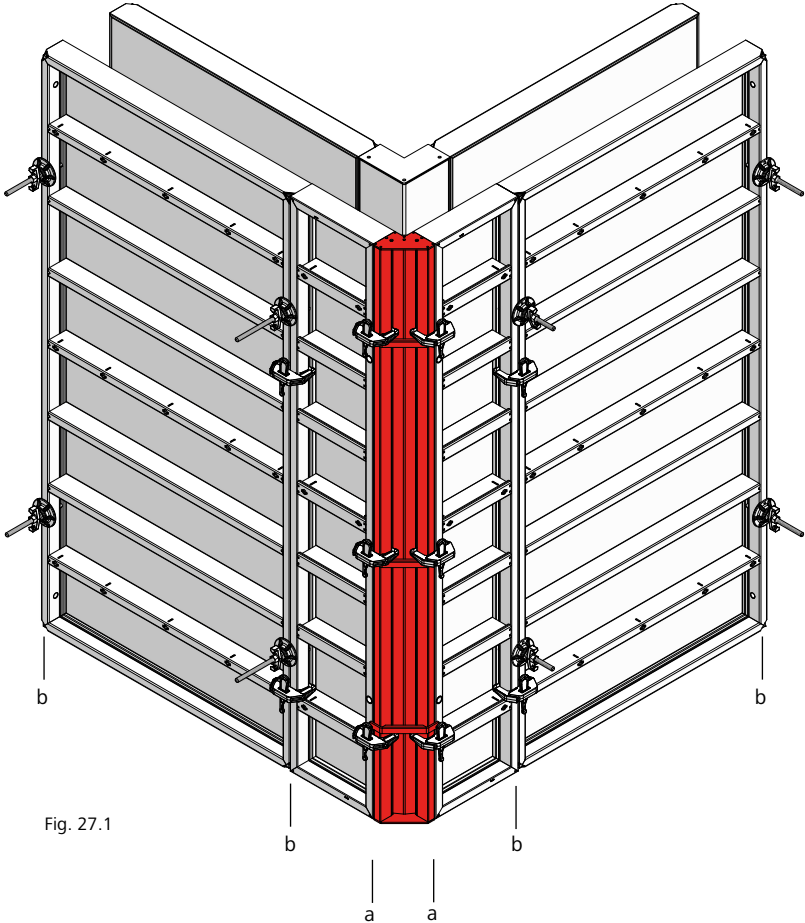

Fig. 27.1

Panel height (in cm)	Number of assembly locks	
	(a)	(b)
330	4	3
270	3	2
135	2	2

Table 27.2

Panel width 1 =
 outside corner 10 = wall thickness (WT) in cm + 15
 Outside corner 5 = wall thickness (WT) in cm + 20

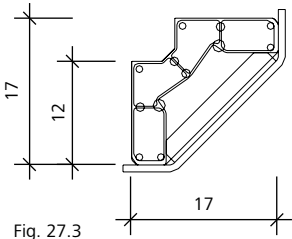

Fig. 27.3

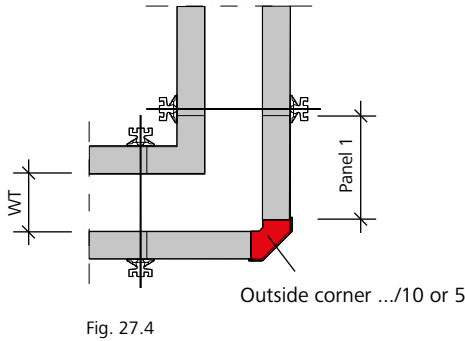

Fig. 27.4

Description	Ref. No.
AS/ST outside corner alu	
330/10	22-140-49
330/5	22-140-15
270/10	22-140-51
270/5	22-140-25
135/10	22-140-53
135/5	22-140-35

Wall Formwork

Height-extended 90° outside corner

Pouring heights of 4.05 m or higher (Fig. 28.1) require the number of assembly locks and alignment rails shown in Table 28.3.

The alignment rails must be attached to the panels with two flange screws 18. Always start attaching the alignment rails at the bottom multi-function profile, i.e. the first alignment rail must be attached to the bottom multifunction profile of the bottom outside corner. Note that the alignment rails must cover the next panel joint and be bolted at the corners (Figures 28.1 and 28.2).

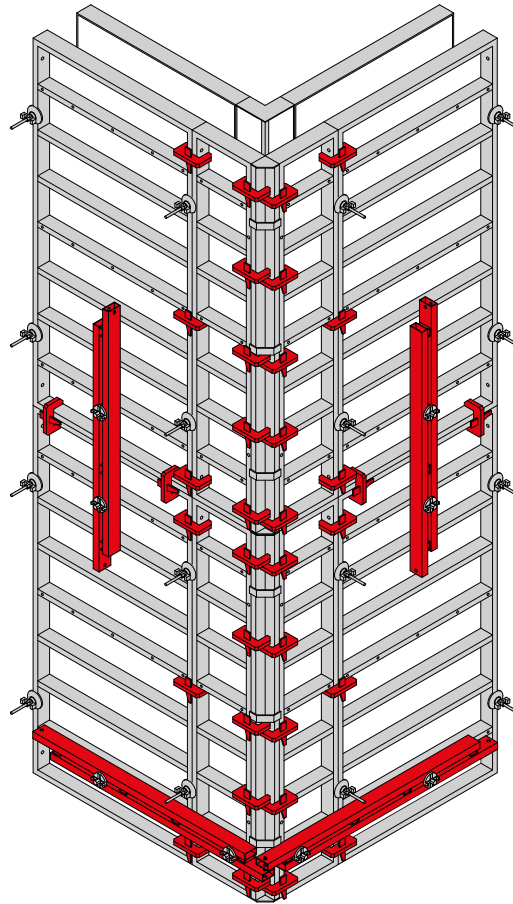

Fig. 28.1 Height 540 cm

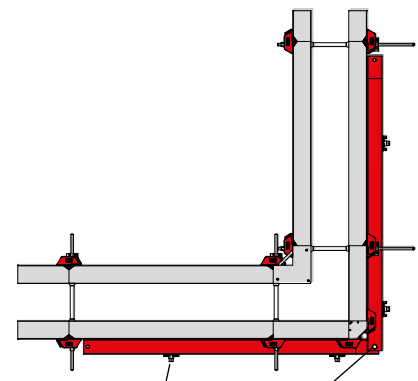

Fig. 28.2

Flange screw 18

Alignment rails bolted at corner

Description	Ref. No.
AS/ST outside corner 330.....	22-140-10
AS/ST outside corner 270.....	22-140-20
AS/ST outside corner 135.....	22-140-30
AS/ST outside corner 90.....	22-140-40
AS alignment rail 50.....	29-201-73
AS alignment rail 125.....	29-201-75

Height-extended outside corner						
Pouring height h [cm]	Number of alignment rails (from bottom to top)					Number of AS assembly locks
	Wall thickness [cm]					
	0-30	31-50	51-75	76-90	91-135	
270 + 135 = 405	-	-	1	1	1	(5 + 2) = 7
270 + 135 + 90 = 495	-	-	1	1	1	(5 + 2 + 2) = 9
270 + 270 = 540	1	1	1	1	1	(5 + 5) = 10
330 + 270 = 600	1	1	1	1	2	(6 + 5) = 11
270 + 270 + 90 = 630	1	1	1	2	2	(5 + 5 + 2) = 12
330 + 330 = 660	1	1	2	3	3	(6 + 6) = 12
270 + 270 + 135 = 675	1	1	2	2	3	(5 + 5 + 2) = 12
270 + 270 + 270 = 810	2	2	3	3	4	(5 + 5 + 5) = 15

Table 28.3

Wall Formwork

90° corner with filler

The filler is attached per panel height with two Uni-assembly locks up to a height of 270 cm or with three RS or Uni-assembly locks for panel height 330 cm.

Wide filler area:

- RS assembly lock from 3.9 to 12.5 cm
- Uni-assembly lock 22 from 0 to 14 cm
- Uni-assembly lock 28 from 0 to 20 cm

An AS alignment rail is attached to the multi-function profile or to the tie holes for stabilisation (one alignment rail per tie hole level) (Fig. 29.2).

The AS/ST aluminium filler can be used for 4, 5, 6 and 8 cm gaps. The filler has tie holes. By rotating them through 180°, two fillers can be used next to each other.

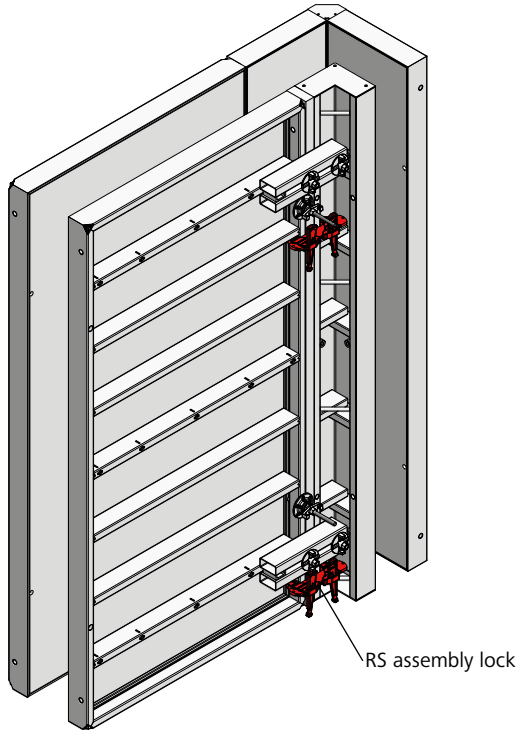

Fig. 29.1

Outside corner with filler area

An AS alignment rail is attached to the multi-function profile or to the tie holes for stabilisation (one alignment rail per tie hole level) (Fig. 29.3).

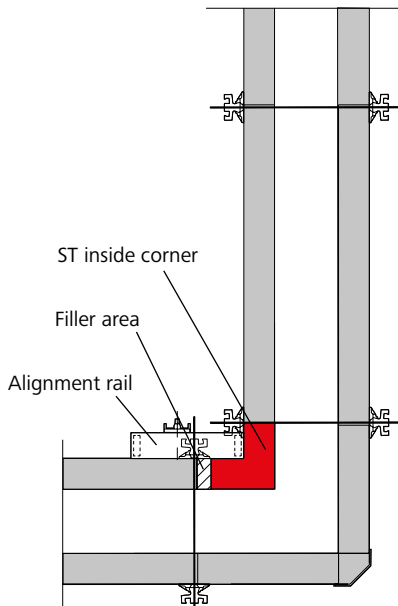

Fig. 29.2

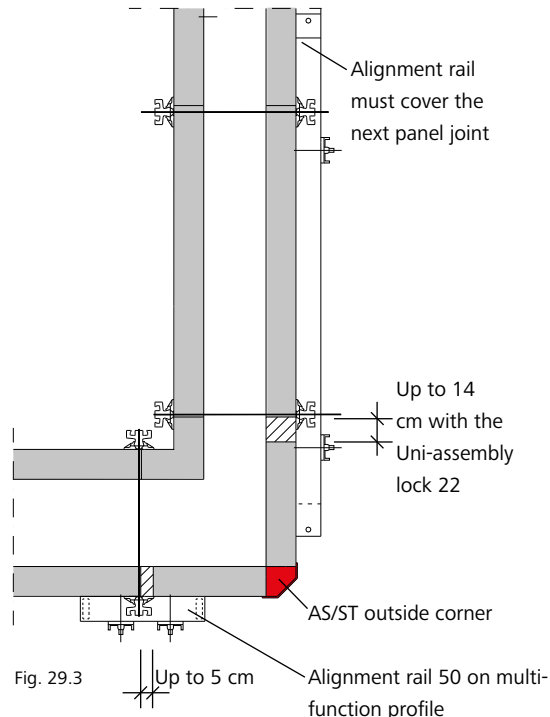

Fig. 29.3

Description	Ref. No.
AS/ST aluminium filler 330/8..	21-270-57
AS/ST aluminium filler 330/6..	21-270-56
AS/ST aluminium filler 330/5..	21-270-58
AS/ST aluminium filler 330/4..	21-270-54
AS/ST aluminium filler 270/8..	21-270-62
AS/ST aluminium filler 270/6..	21-270-61
AS/ST aluminium filler 270/5..	21-270-60
AS/ST aluminium filler 270/4..	21-270-59
AS/ST aluminium filler 135/8..	21-270-67
AS/ST aluminium filler 135/6..	21-270-66
AS/ST aluminium filler 135/5..	21-270-65
AS/ST aluminium filler 135/4..	21-270-64
Uni-assembly lock 22	29-400-85
Uni-assembly lock 28	29-400-90
RS assembly lock.....	23-807-70

Wall Formwork

90° corner – combinations

A 90° corner can be made in increments of 5 cm with just a few panel widths.

The AS/ST aluminium filler 5 can be used for a 5 cm gap (Fig. 30.3). A 10 cm gap can be filled with two AS/ST aluminium fillers 5 and the M cross stiffener 44 (Fig. 30.4). The filler has tie holes.

For the width and number of StarTec/AluStar panels and AS/ST aluminium fillers for wall thickness between 15 and 50 cm refer to Table 30.5.

AS/ST fillers with widths 4, 6 and 8 cm can be used for intermediate sizes.

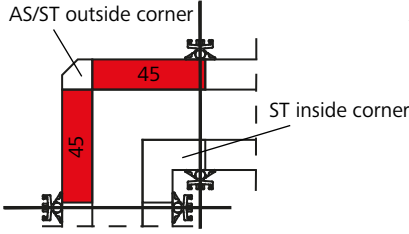

Fig. 30.1 Wall thickness 20 cm

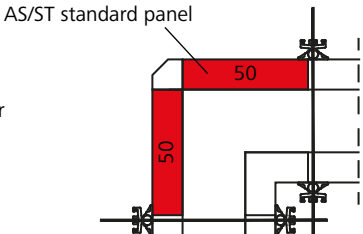

Fig. 30.2 Wall thickness 25 cm

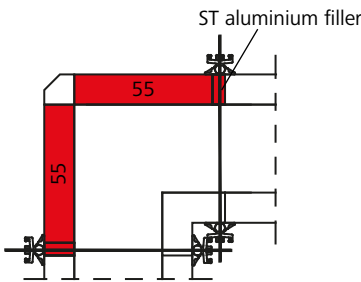

Fig. 30.3 Wall thickness 35 cm

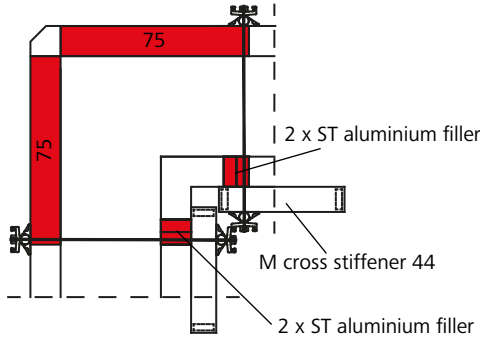

Fig. 30.4 Wall thickness 40 cm

Wall thickness (in cm)	AS/ST outside corner	ST inside corner	AS/ST standard panel				AS/ST aluminium filler 5
			45	50	55	75	
15	1	1	2				2 inside
20	1	1	2				
25	1	1		2			
30	1	1			2		
35	1	1			2		2 outside
40	1	1				2	4 inside
45	1	1				2	2 outside
50	1	1				2	

Table 30.5 Combinations

Description	Ref. No.
AS/ST aluminium filler 330/8..	21-270-57
AS/ST aluminium filler 330/6..	21-270-56
AS/ST aluminium filler 330/5..	21-270-58
AS/ST aluminium filler 330/4..	21-270-54
AS/ST aluminium filler 270/8..	21-270-62
AS/ST aluminium filler 270/6..	21-270-61
AS/ST aluminium filler 270/5..	21-270-60
AS/ST aluminium filler 270/4..	21-270-59
AS/ST aluminium filler 135/8..	21-270-67
AS/ST aluminium filler 135/6..	21-270-66
AS/ST aluminium filler 135/5..	21-270-65
AS/ST aluminium filler 135/4..	21-270-64
M cross stiffener 44	29-401-02

Hinged corners

Acute and obtuse angled corners are formed using hinged inside and outside corners (Figures 31.1 and 31.2).

At the outside corner, alignment rails must be attached to the multi-function profiles of the adjacent panels using flange screws 18.

If the inside angle α is greater than 100° , alignment rails and a wooden blocking are also required on the inside (Fig. 31.1).

Timber fillers and Uni-assembly locks 22 are used for length compensation.

Side length

- Outside corner 7.5 cm
- Inside corner 30 cm

Adjustment range

60° to 180°

Note

Acute and obtuse angled corners can also be formed using hinged corners and multi-purpose panels (see page ST/AS-64).

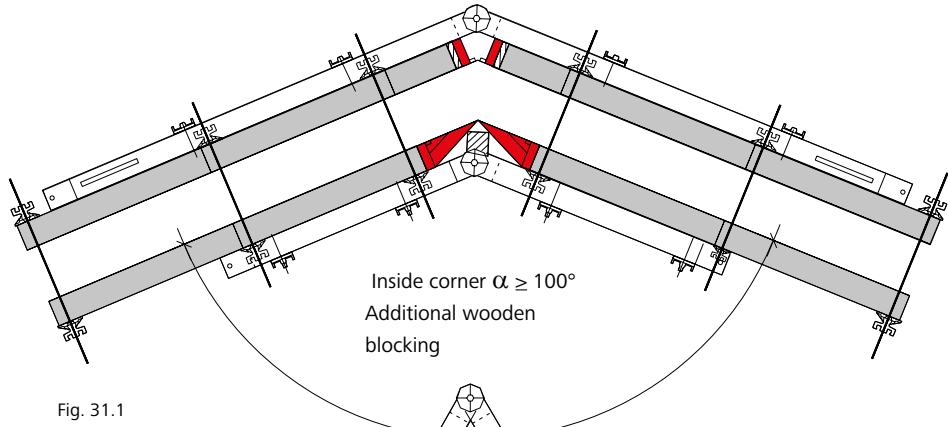

Fig. 31.1

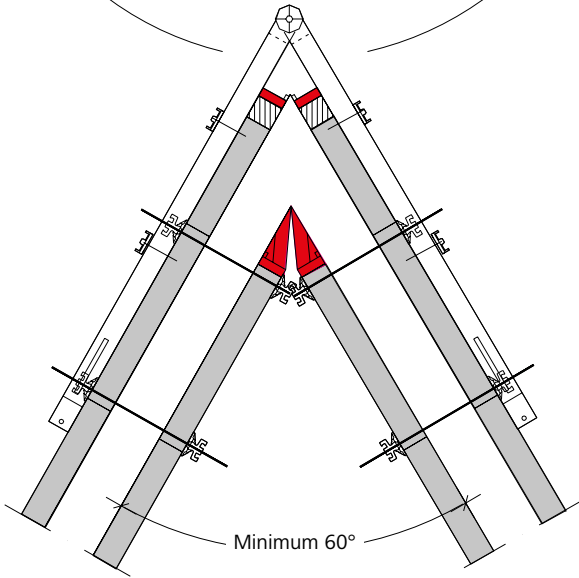

Fig. 31.2

Description	Ref. No.
StarTec HIC 330/30	21-270-20
AluStar HIC 270/30	21-270-00
AluStar HIC 135/30	21-270-10
StarTec HOC 330/7.5	21-280-20
AluStar HOC 270/7.5	21-280-00
AluStar HOC 135/7.5	21-280-10

Hinged corners

If the inside angle α is less than 100° , alignment rails and a wooden blocking are not required on the inside (Fig. 32.1).

Table 32.2 shows the different filler areas Y (filler) depending on the wall thickness (WT) and the inside angle α .

Note

Acute and obtuse angled corners can also be formed using hinged corners and multi-purpose panels (see page ST/AS-64).

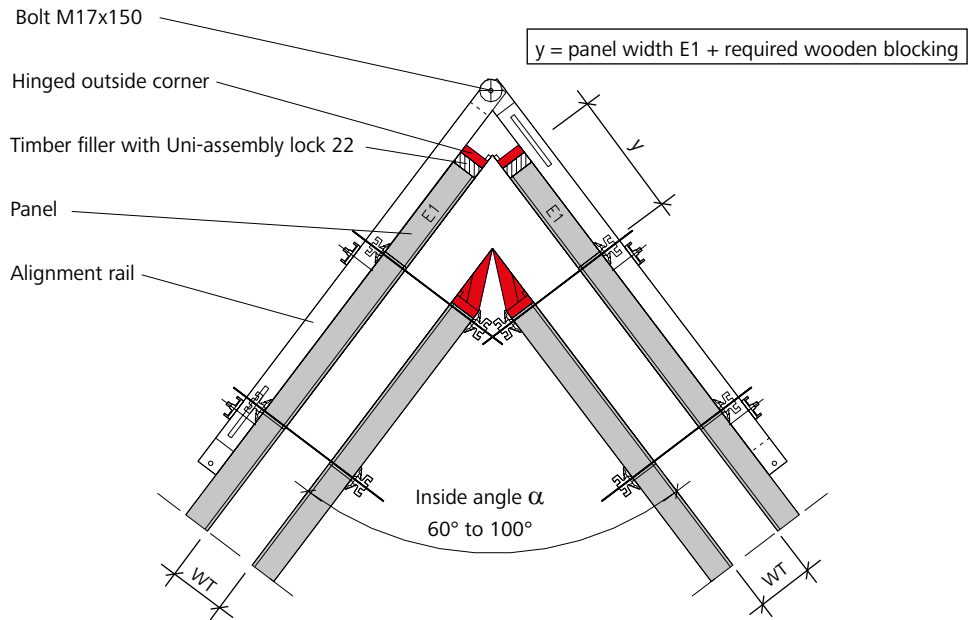

Fig. 32.1

WT = wall thickness

$$\text{Equation to calculate the width } y \text{ (in cm)} = \frac{WT}{\tan \frac{\alpha}{2}} + 22.5$$

Inside angle (α)	Wall thickness (WT)						
	24 cm	25 cm	30 cm	35 cm	40 cm	45 cm	50 cm
60°	Y = 64.1	Y = 65.8	Y = 74.5	Y = 83.1	Y = 91.8	Y = 100.4	Y = 109.1
65°	Y = 60.2	Y = 61.7	Y = 69.6	Y = 77.4	Y = 85.3	Y = 93.1	Y = 101.0
70°	Y = 56.8	Y = 58.2	Y = 65.3	Y = 72.5	Y = 79.6	Y = 86.8	Y = 93.9
75°	Y = 53.8	Y = 55.1	Y = 61.6	Y = 68.1	Y = 74.6	Y = 81.1	Y = 87.7
80°	Y = 51.1	Y = 52.3	Y = 58.3	Y = 64.2	Y = 70.2	Y = 76.1	Y = 82.1
85°	Y = 48.7	Y = 49.8	Y = 55.2	Y = 60.7	Y = 66.2	Y = 71.6	Y = 77.1
90°	Y = 46.5	Y = 47.5	Y = 52.5	Y = 57.5	Y = 62.5	Y = 67.5	Y = 72.5
95°	Y = 44.5	Y = 45.4	Y = 50.0	Y = 54.6	Y = 59.2	Y = 63.7	Y = 68.3
100°	Y = 42.6	Y = 43.5	Y = 47.7	Y = 51.9	Y = 56.1	Y = 60.3	Y = 64.5
105°	Y = 40.9	Y = 41.7	Y = 45.5	Y = 49.4	Y = 53.2	Y = 57.0	Y = 60.9
110°	Y = 39.3	Y = 40.0	Y = 43.5	Y = 47.0	Y = 50.5	Y = 54.0	Y = 57.5
115°	Y = 37.8	Y = 38.4	Y = 41.6	Y = 44.8	Y = 48.0	Y = 51.2	Y = 54.4
120°	Y = 36.4	Y = 36.9	Y = 39.8	Y = 42.7	Y = 45.6	Y = 48.5	Y = 51.4
125°	Y = 35.0	Y = 35.5	Y = 38.1	Y = 40.7	Y = 43.3	Y = 45.9	Y = 48.5
130°	Y = 33.7	Y = 34.2	Y = 36.5	Y = 38.8	Y = 41.2	Y = 43.5	Y = 45.8
135°	Y = 32.4	Y = 32.9	Y = 34.9	Y = 37.0	Y = 39.1	Y = 41.1	Y = 43.2
140°	Y = 31.2	Y = 31.6	Y = 33.4	Y = 35.2	Y = 37.1	Y = 38.9	Y = 40.7
145°	Y = 30.1	Y = 30.4	Y = 32.0	Y = 33.5	Y = 35.1	Y = 36.7	Y = 38.3
150°	Y = 28.9	Y = 29.2	Y = 30.5	Y = 31.9	Y = 33.2	Y = 34.6	Y = 35.9
155°	Y = 27.8	Y = 28.0	Y = 29.2	Y = 30.3	Y = 31.4	Y = 32.5	Y = 33.6
160°	Y = 26.7	Y = 26.9	Y = 27.8	Y = 28.7	Y = 29.6	Y = 30.4	Y = 31.3
165°	Y = 25.7	Y = 25.8	Y = 26.4	Y = 27.1	Y = 27.8	Y = 28.4	Y = 29.1
170°	Y = 24.6	Y = 24.7	Y = 25.1	Y = 25.6	Y = 26.0	Y = 26.4	Y = 26.9
175°	Y = 23.5	Y = 23.6	Y = 23.8	Y = 24.0	Y = 24.2	Y = 24.5	Y = 24.7
180°	Y = 22.5	Y = 22.5	Y = 22.5	Y = 22.5	Y = 22.5	Y = 22.5	Y = 22.5

Table 32.2

Wall Formwork

Stripping corner

The ST stripping corners 330, 270 and 135 allow the shaft formwork to be removed safely and quickly from the poured shaft walls, for example, without damaging the walls or formwork. They function according to the "jumping jack" principle.

The stripping corner is a three-piece design to permit inward movement of the lateral parts.

The side length is 25 cm.

The height of the stripping corner can be increased easily (Fig. 33.1).

After pouring and when the concrete has set sufficiently, all stripping corners are activated (pages ST/AS-36 to -38) and the entire formwork can be lifted out of the shaft as one single unit with a 4-rope crane sling (Fig. 33.3). There is no need to disassemble the formwork. For details see Figures 33.4 A and 33.5 B.

Note

- Before pouring, cover the joints on the sides of the stripping corner with adhesive tape to make it easier to clean.
- Make sure the entire formwork is completely removed from the poured walls before lifting it by crane.

Attention

When slinging with several strands, only two strands may be considered to be load-bearing according to the Berufsgenossenschaft (the German employers' liability insurance association). This does not apply if it has been ensured that the load is distributed evenly over further strands or if the permissible loading of the individual strands is not exceeded in the event of an unequal load distribution.

The maximum permissible loading of the crane eye per stripping corner is 10 kN (1 ton). This results in a permissible total weight of the complete shaft formwork of 40 kN (4 tons) if it has been ensured that the load is evenly distributed (the contractor is responsible for this). Otherwise, the permissible total weight is 20 kN (2 tons).
 The permissible loading of the AS crane hook is 15 kN (1.5 tons). This results in a permissible total weight of the complete shaft formwork of 60 kN (6 tons) if it has been ensured that the load is evenly distributed (the contractor is responsible for this). Otherwise, the permissible total weight is 30 kN (3 tons).
 For higher loads, a spreader beam must be used.

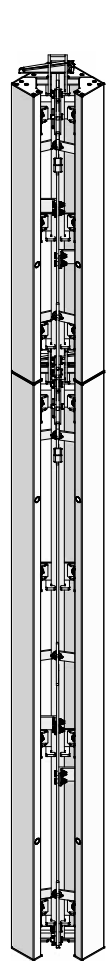

Fig. 33.1

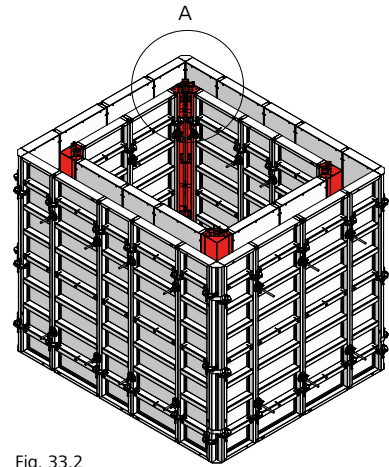

Fig. 33.2

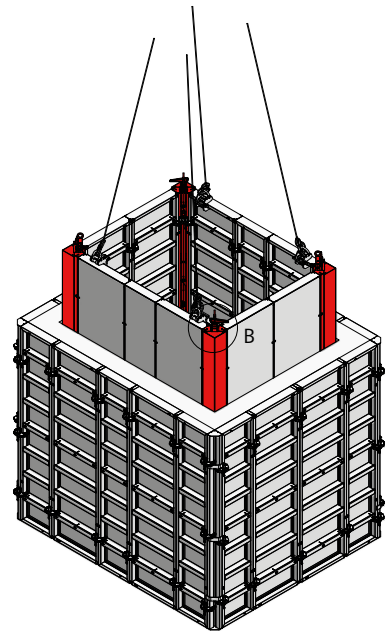

Fig. 33.3

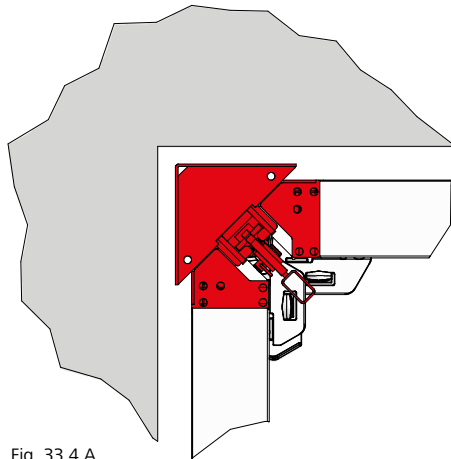

Fig. 33.4 A

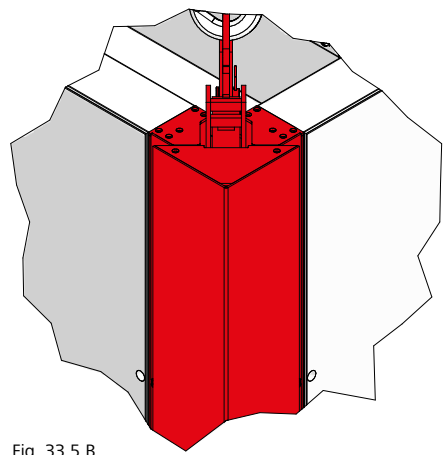

Fig. 33.5 B

Description	Ref. No.
ST stripping corner	
StarTec SC 330/25.....	21-262-05
StarTec SC 270/25.....	21-262-10
StarTec SC 135/25.....	21-262-30
Adhesive tape.....	41-912-10

Stripping corner

Attachment and position of assembly locks

The function of the ST stripping corners is ensured when the AS assembly locks are fitted to the stripping corner in the permitted areas.

No assembly locks can be attached and positioned in the grey shaded areas.

Height 330 cm requires three assembly locks (Fig. 34.1).

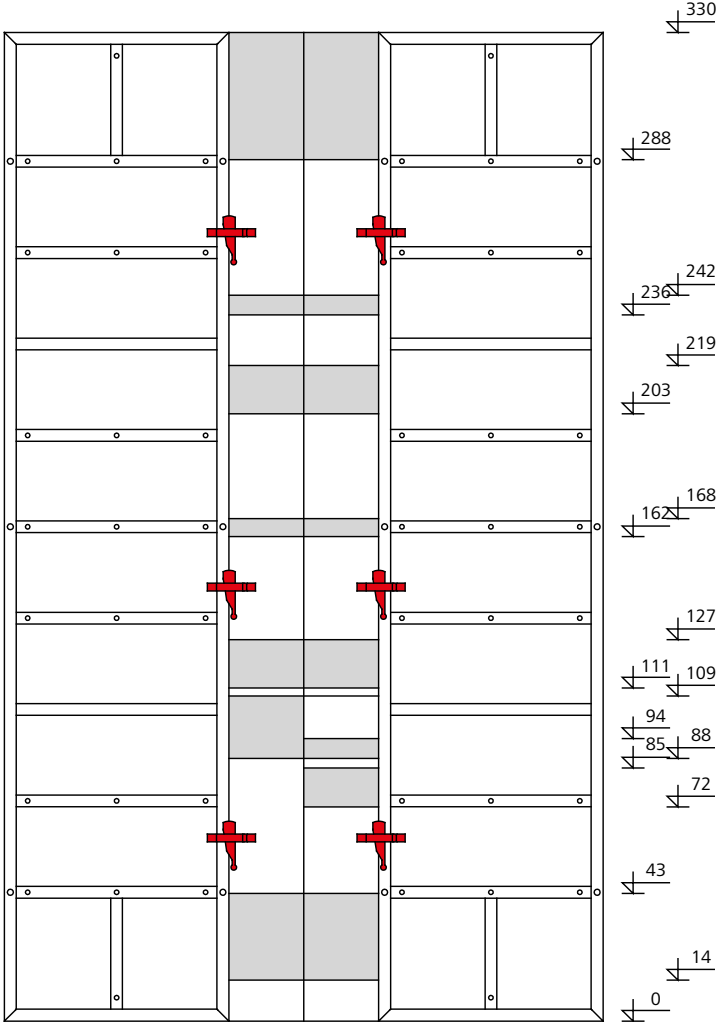
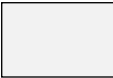

Fig. 34.1 ST stripping corner 330/25

 No assembly locks possible in grey shaded areas!

Description	Ref. No.
StarTec SC 330/25.....	21-262-05

Stripping corner

Attachment and position of assembly locks

The function of the ST stripping corners is ensured when the AS assembly locks are fitted to the stripping corner in the permitted areas.

No assembly locks can be attached and positioned in the grey shaded areas.

Up to a height of 270 cm two assembly locks are required (Figures 35.1 and 35.2).

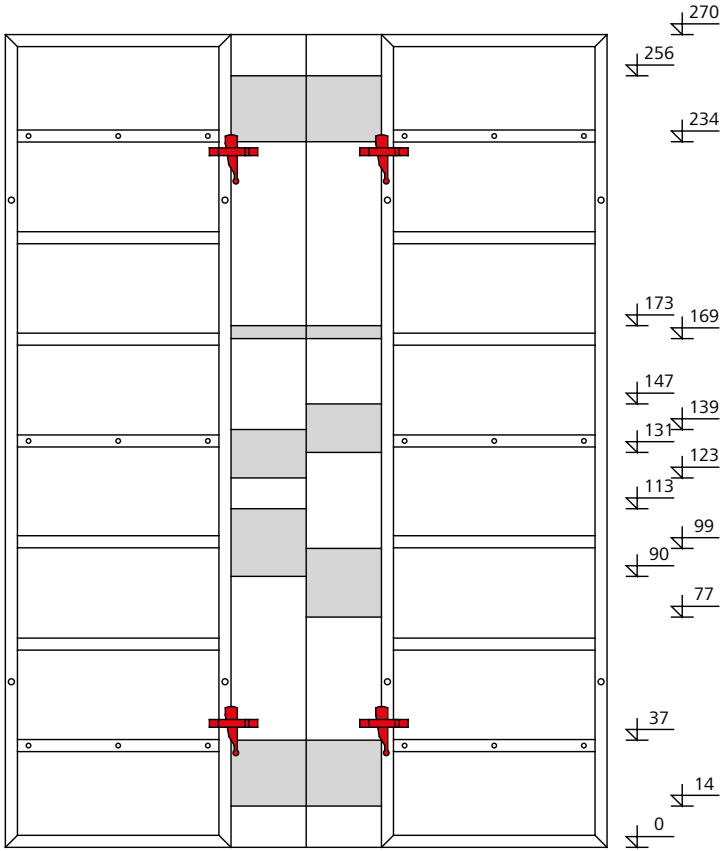

Fig. 35.1 ST stripping corner 270/25

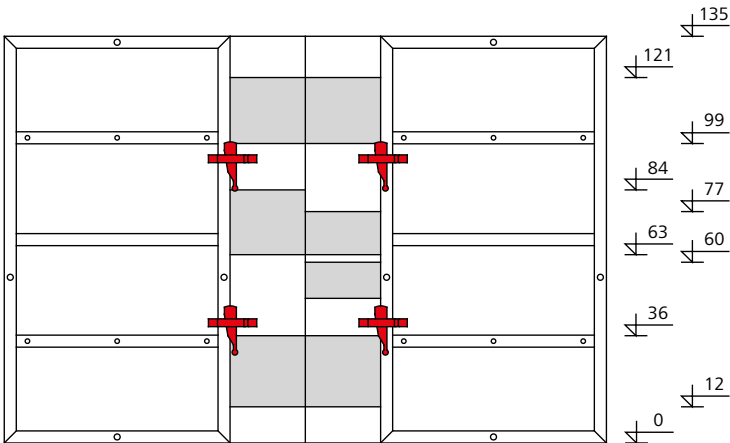



Fig. 35.2 ST stripping corner 135/25

 No assembly locks possible in grey shaded areas!

Description	Ref. No.
Stripping corner	
StarTec SC 270/25.....	21-262-10
StarTec SC 135/25.....	21-262-30

Stripping corner

Set-up and handling

1. Insert the wedge integrated into the stripping corner into the connecting device (Fig. 36.6 C).
2. Connect stripping corners and formwork panels (see pages ST/AS-34 and -35).
3. Remove the wedges after pouring and prior to stripping.
4. Activate the stripping corner with a crowbar. The bell-crank lever is pushed upwards using the crowbar. The crowbar can be applied at the bottom at position A (Fig. 36.3 A) or in the middle at position B (Fig. 36.4 B). This breaks the bond between the formwork facing and the concrete without much effort.

Pages ST/AS-37 and -38 describe how to activate the stripping corner with the stripping support.

5. Attach the stripping corners with crane slings to the crane gear. Make sure the entire formwork is completely removed from the poured walls before lifting it by crane.
6. The entire formwork is moved in one single lift and detached from the crane when it is in its new position.
7. The stripping corner can be reset for the next pour by positioning the crowbar at position C (Fig. 36.5 C) and pushing the bell-crank lever down.
8. Reinsert the wedge into the connecting device (Fig. 36.6 C).
9. A few hammer blows to the wedge will move the lateral parts of the stripping corner outwards and keep them in the pouring

position.

Note
Returning the stripping corner to its original position by hitting the bell-crank lever with a hammer can result in damage and is not permitted.

Height extension
Two stripping corners can be connected to each other easily by joining their bell-crank levers. The bolt must be secured with a cotter pin through the crane eye (Fig. 36.1 D).

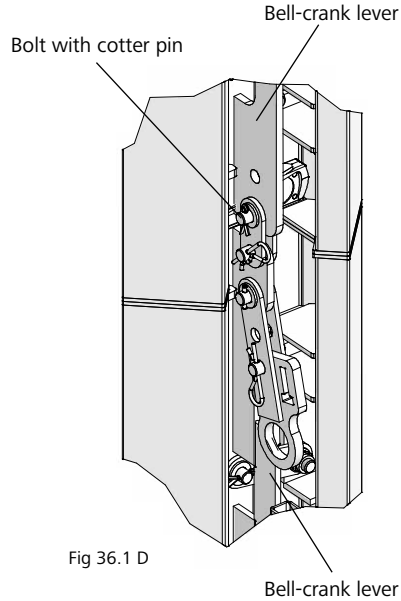

Fig 36.1 D

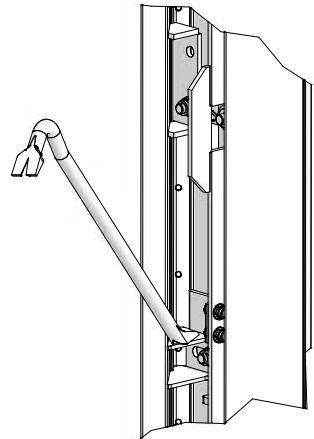

Fig. 36.4 B

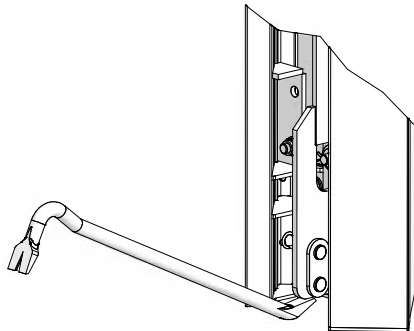

Fig. 36.3 A

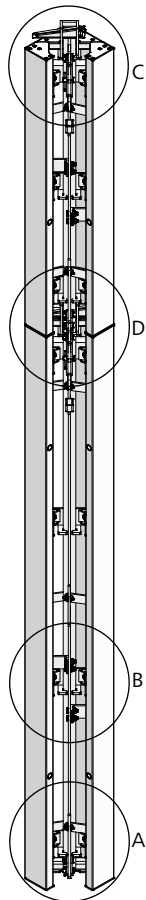

Fig. 36.2

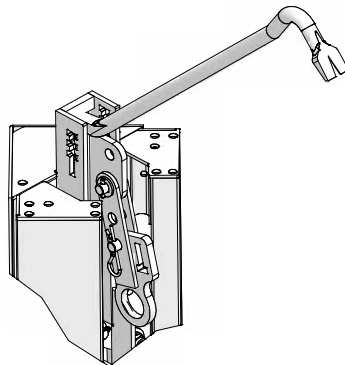

Fig. 36.5 C

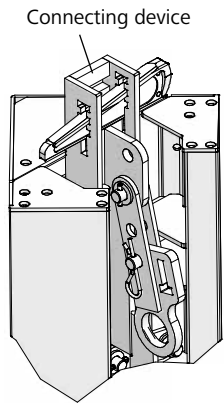

Fig. 36.6 C Pouring position

Description	Ref. No.
StarTec SC 330/25.....	21-262-05
StarTec SC 270/25.....	21-262-10
StarTec SC 135/25.....	21-262-30

Stripping corner

Stripping support

The stripping support (Fig. 37.1) is used to easily activate the stripping corner from above

with a power screwdriver, a ratchet spanner or a spanner. Tools with width across flats of 27, 30 or 36 mm are to be used.

Stripping corner tool

The stripping corner tool (Fig. 37.2) also enables the stripping corner to be screwed back to its original position with a power screwdriver, a ratchet spanner or a spanner. Tools with width across flats of 36 mm are to be used.

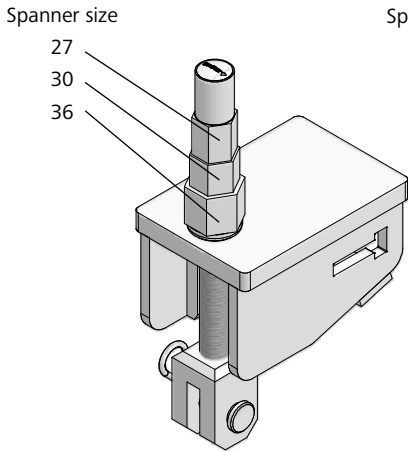

Fig. 37.1

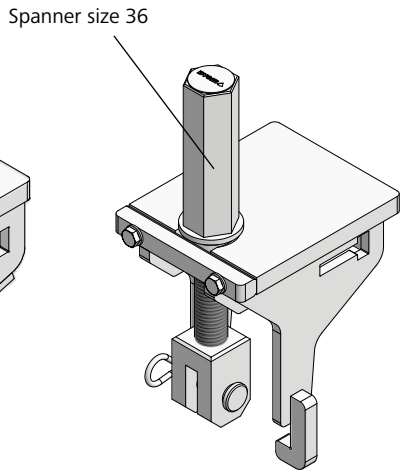

Fig. 37.2

Assembly

1. Place the stripping support onto the connecting device at the top of the stripping corner. Make sure the suspension is inclined downwards (Fig. 37.3).
2. Connect the stripping support to the stripping corner with the head bolt 16/40 and cotter pin 4 that are both integrated into the tensioning screw of the stripping support (Fig. 37.3).
3. Lock the stripping support to the stripping corner by driving the stripping corner's wedge with a few hammer blows into the opening of the stripping support (Fig. 37.3).

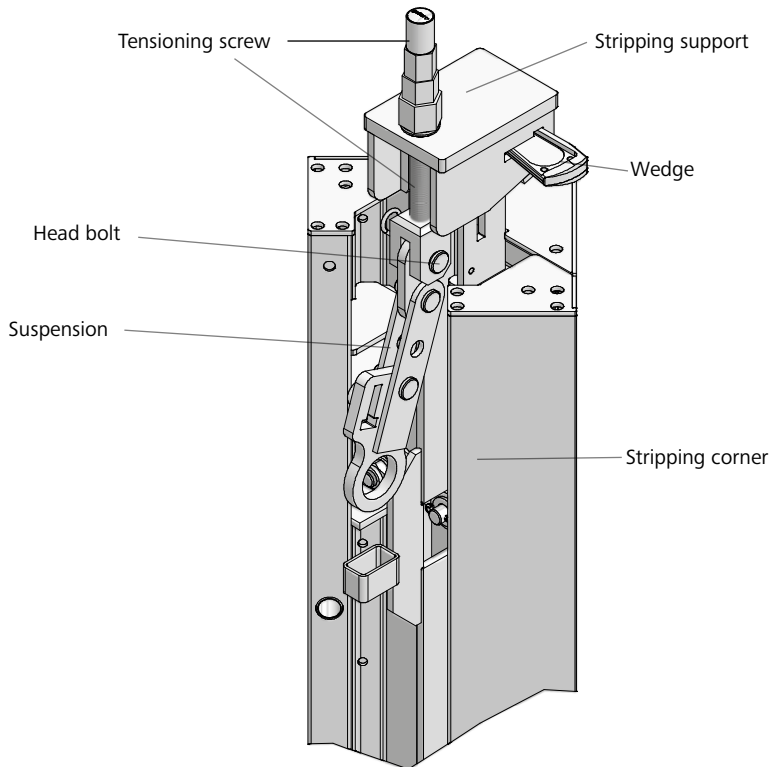

Fig. 37.3

Description	Ref. No.
Stripping support	79-306-30
Stripping corner tool.....	29-306-32
Spanner	
size 27	29-800-10
size 36	29-800-15

Stripping corner

Working principle of the stripping support / stripping corner tool

The stripping support has three hexagonal nuts that are operated with tools with width across flats of 27, 30 and 36 mm. The stripping corner tool has a hexagonal nut with widths across flats of 36 mm.

Turning the hexagonal nut on the tensioning screw with a power screwdriver (Fig. 38.1), a ratchet spanner (Fig. 38.2) or a spanner moves the bell-crank lever upwards (Fig. 38.5).

This activates the stripping corner and separates the shaft formwork from the poured walls (Fig. 38.4).

When the shaft formwork has been relocated, the stripping corners can be screwed back into their original position using the stripping corner tool (Fig. 38.6).

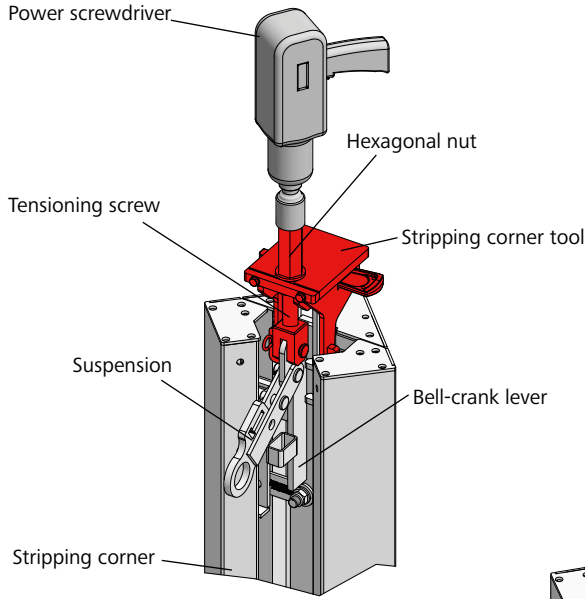

Fig. 38.1

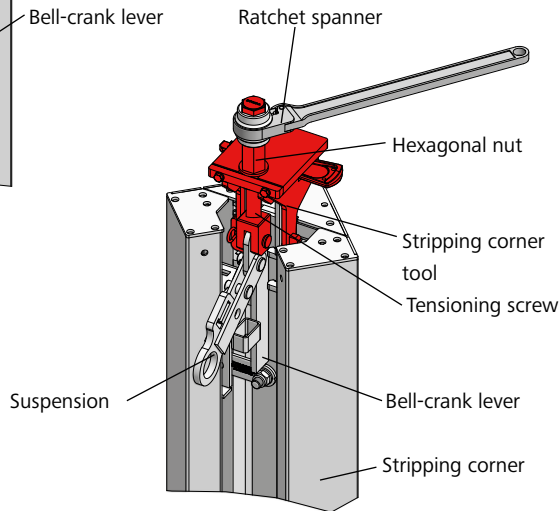

Fig. 38.2

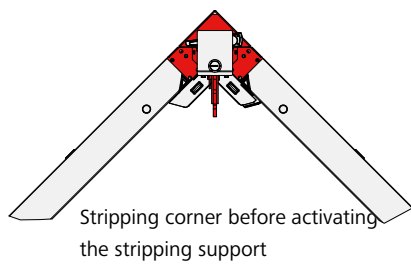

Fig. 38.3

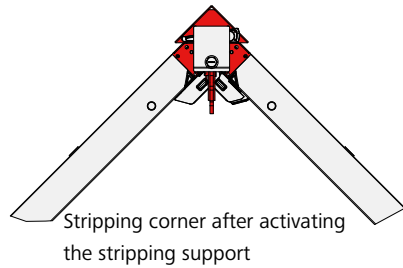

Fig. 38.4

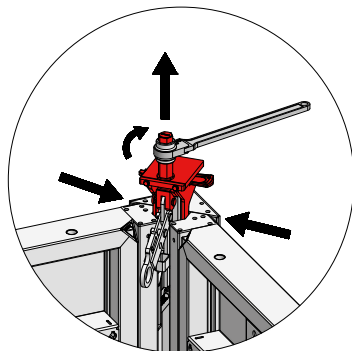

Fig. 38.5

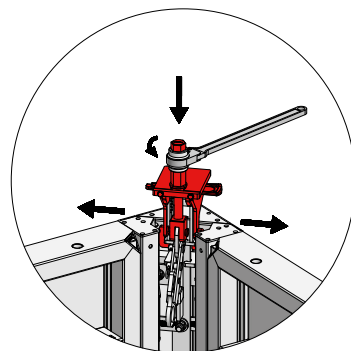

Fig. 38.6

Description	Ref. No.
Stripping support	79-306-30
Stripping corner tool.....	29-306-32
Spanner	
size 27	29-800-10
size 36	29-800-15

Stripping corner

The ST stripping corner can also be used as a stripping aid. In this case, the stripping corner is used to reduce the tension between the panels so that they can easily be removed from the poured wall between the corners.

Steps

- 1. Remove the AS assembly locks connecting the stripping corners to the panels (Fig. 39.1).
- 2. Activate the ST stripping corner (Fig. 39.2 and pages ST/AS-36 to -38).
- 3. Lift the ST stripping corners out of their position, then strip the panels (Fig. 39.3).

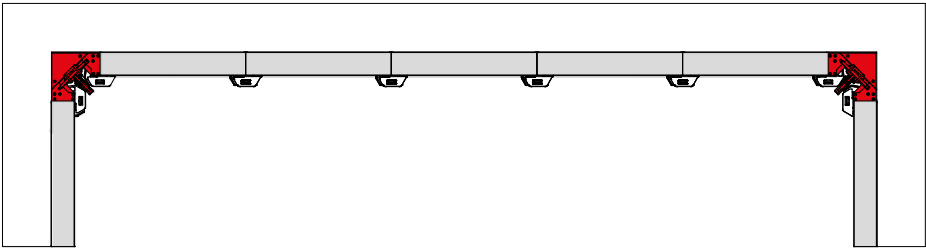

Fig. 39.1

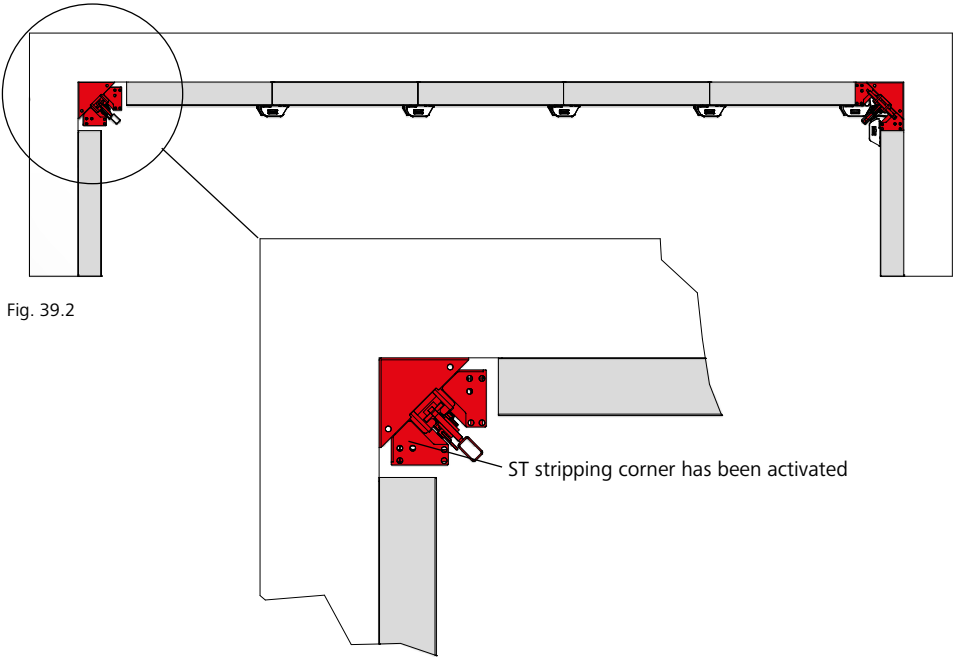

Fig. 39.2

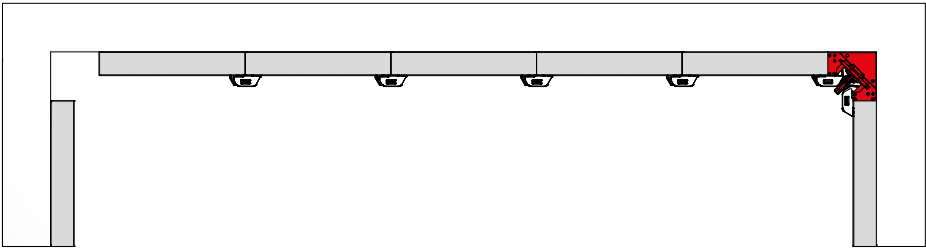

Fig. 39.3

Wall Formwork

Length compensation

Gaps up to 14 cm can be formed on site using a corresponding timber filler (Figures 40.1 and 40.2) or an ST/AS aluminium filler (Fig. 40.3) and Uni-assembly locks 22 (for gaps up to 20 cm Uni-assembly locks 28 are used).

The ST/AS fillers (Fig. 40.3) can be anchored. By rotating them through 180°, two fillers also can be used next to each other.

The reinforcement is achieved with alignment rails (Figures 40.1 and 40.2). For the use of alignment rails refer to Table 3 on page ST/AS-50.

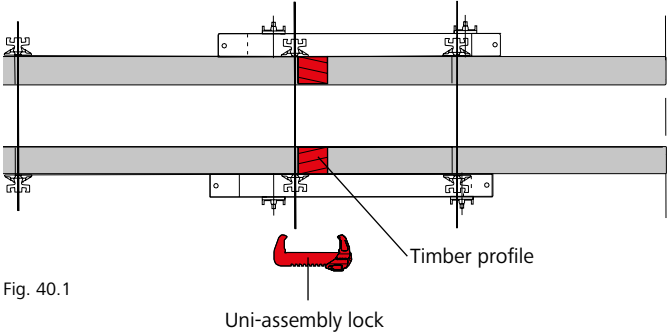

Fig. 40.1

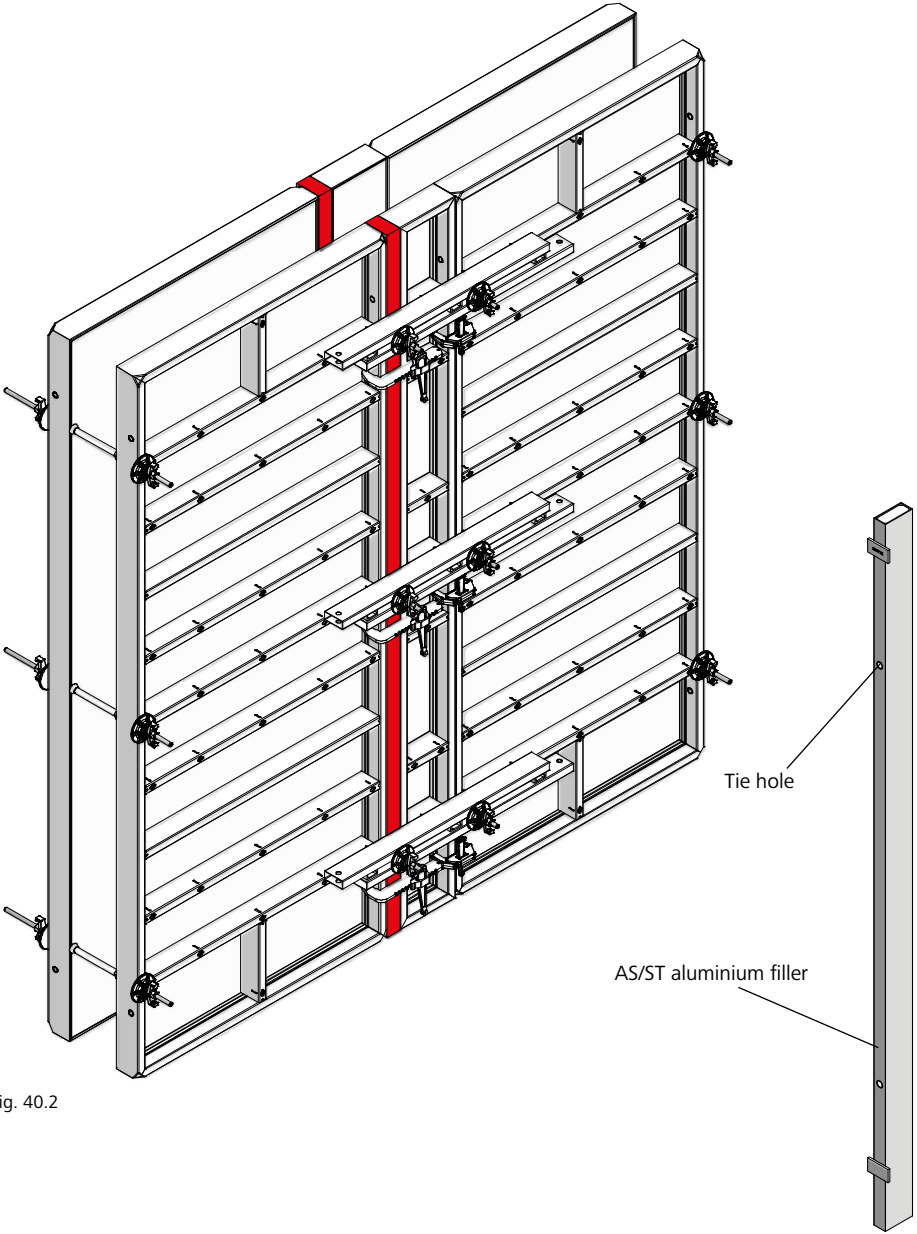

Fig. 40.2

Fig. 40.3

Description	Ref. No.
Uni-assembly lock 22.....	29-400-85
Uni-assembly lock 28.....	29-400-90
AS/ST aluminium filler 330/8..	21-270-57
AS/ST aluminium filler 330/6..	21-270-56
AS/ST aluminium filler 330/5..	21-270-58
AS/ST aluminium filler 330/4..	21-270-54
AS/ST aluminium filler 270/8..	21-270-62
AS/ST aluminium filler 270/6..	21-270-61
AS/ST aluminium filler 270/5..	21-270-60
AS/ST aluminium filler 270/4..	21-270-59
AS/ST aluminium filler 135/8..	21-270-67
AS/ST aluminium filler 135/6..	21-270-66
AS/ST aluminium filler 135/5..	21-270-65
AS/ST aluminium filler 135/4..	21-270-64

Length compensation

Timber profile

Length compensation greater than 14 cm (Figures 41.1 and 41.2) can be achieved with a timber profile (Fig. 41.4) and a facing cut to the right size. Reinforcement is achieved with alignment rails which are attached with flange screws to the multi-function profiles. For problem areas (Figures 41.5 and 41.6) the forming face is attached to the panels with timber profiles.

Timber profiles are always delivered in pairs.

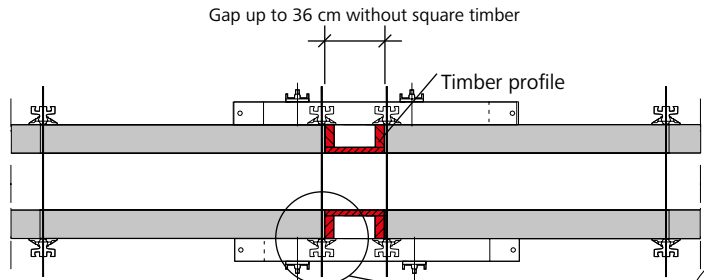

Fig. 41.1

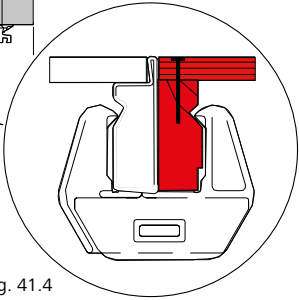

Fig. 41.4

ST compensation plate

Alternatively, the ST compensation plate can be used for length compensation between 8 and 20 cm (Fig. 41.3). It is attached to the panel with two AS assembly locks. Alignment rails are to be used for bridging and reinforcement purposes.

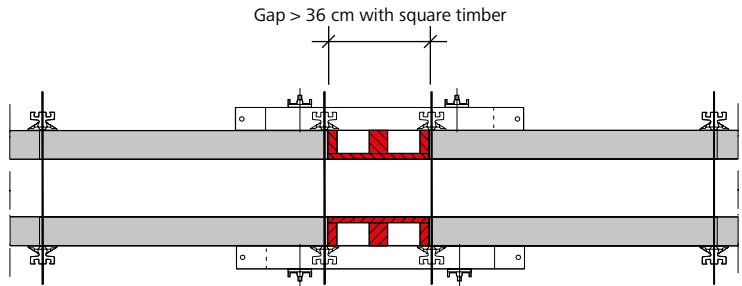

Fig. 41.2

Note

For the use of alignment rails refer to the table on page ST/AS-50.

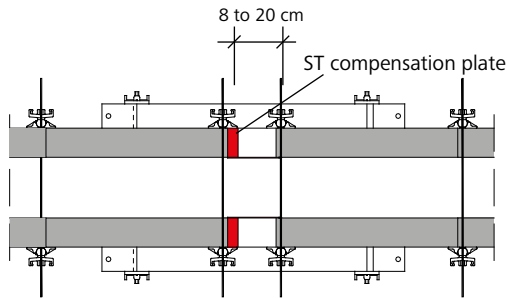

Fig. 41.3

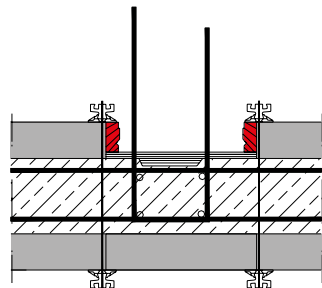

Fig. 41.5

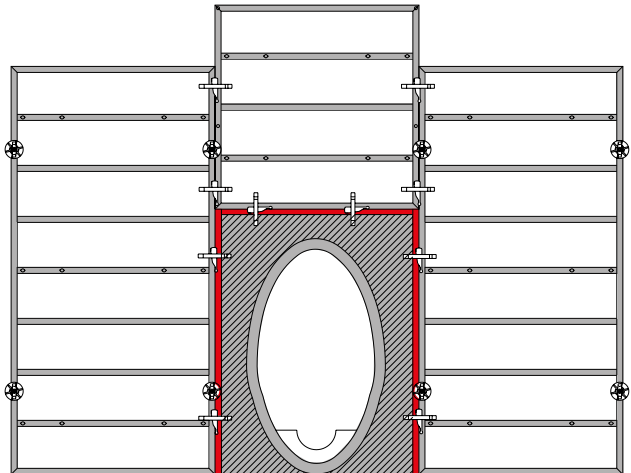

Fig. 41.6

Description	Ref. No.
AS/ST timber profile 330/21 ...	29-200-07
AS/ST timber profile 270/21 ...	29-200-03
AS/ST timber profile 135/21 ...	29-200-05
ST compensation plate 270/2021-300-20	
ST compensation plate 135/2021-300-30	

T wall connection

A T wall connection is made using two inside corners (Figures 42.1 to 42.5).

Different wall widths can be compensated for using timber profiles (Fig. 42.4) or timber fillers (Fig. 42.5).

For the use of alignment rails refer to the table on page ST/AS-50.

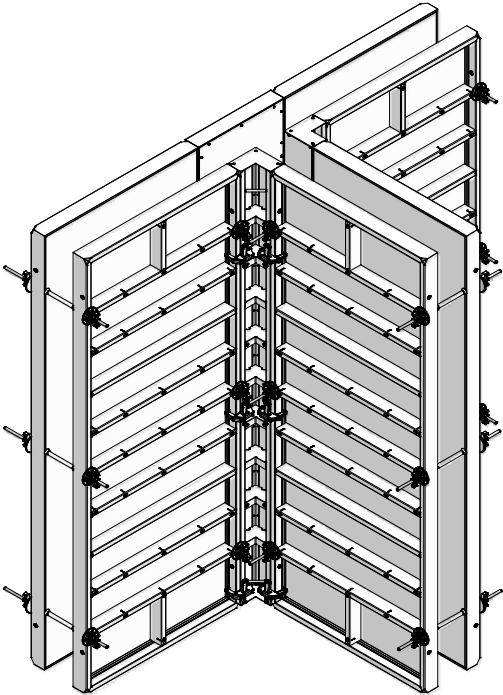

Fig. 42.1

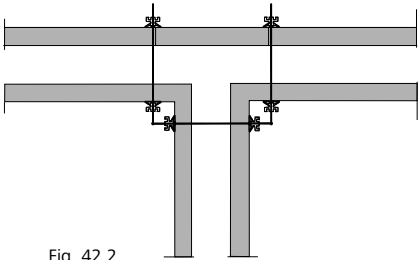

Fig. 42.2

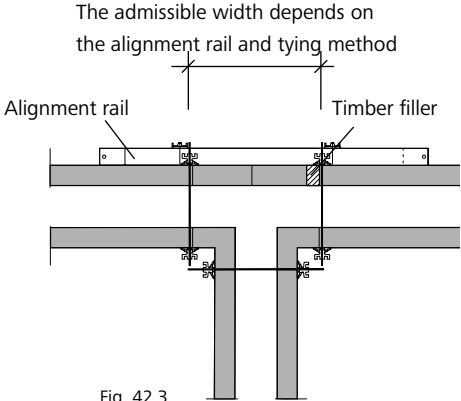

Fig. 42.3

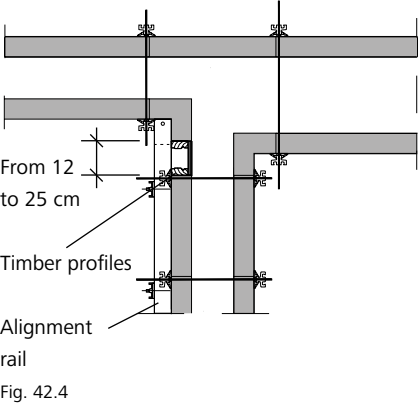

Fig. 42.4

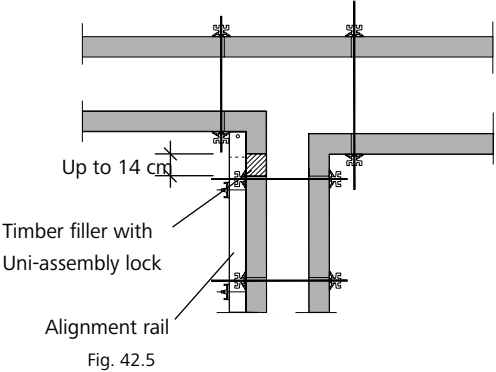

Fig. 42.5

Connection to existing walls

Figures 43.1 to 43.7 show various options for connecting formwork to an existing wall. Depending on the wall layout and conditions on the construction site, the most suitable solution may vary from case to case.

Always make sure the formwork is firmly pressed up against the existing wall and attached to it without gaps in order to avoid leakage of the fresh concrete and a patchy concrete surface.

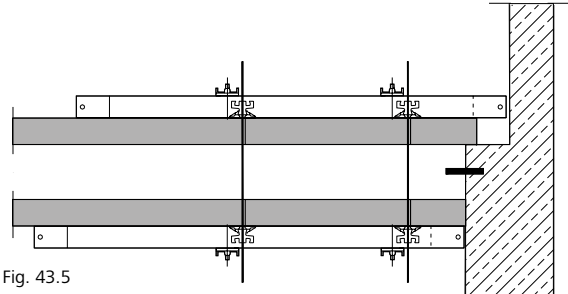
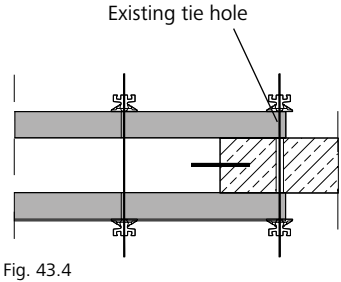
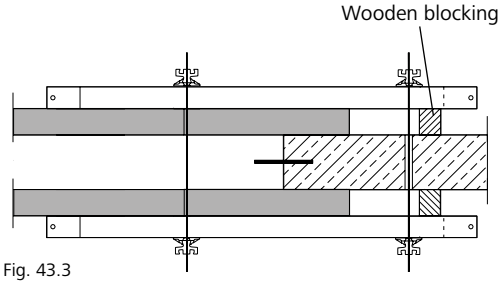
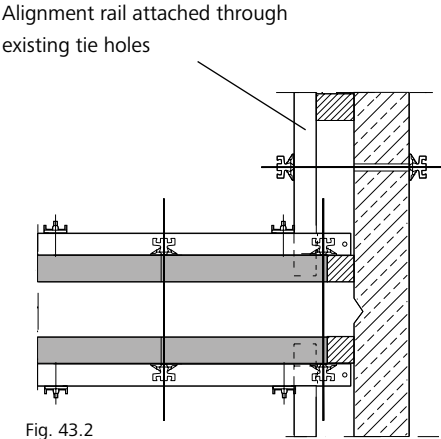
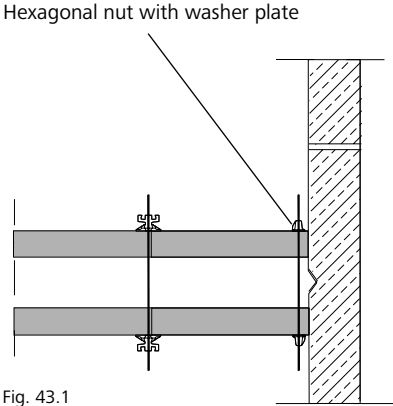
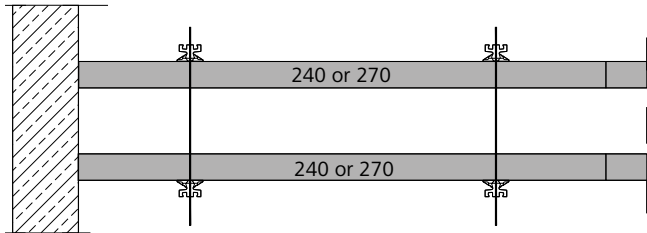
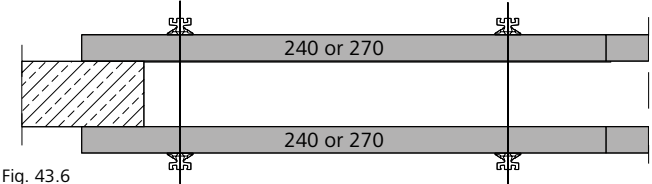

Fig. 43.5



Wall Formwork

Stop ends

With outside corners and standard panels

Stop ends can also be formed using outside corners and standard panels (Figures 44.1 to 44.3).

Panels that are 50 cm wide or wider require additional bracing with alignment rails above a formwork height of 270 cm (Fig. 44.3). One alignment rail is required for reinforcement at each tie hole level.

Rounded stop ends up to 60 cm thick can be formed using a half-shell of the circular steel column formwork Circo. It is attached with a Uni-assembly lock 22 (Fig. 44.4).

Please observe the Circo Circular Column Formwork Technical Instruction Manual.

For the number of assembly locks required at the outside corner and at the first panel joint refer to Table 44.5.

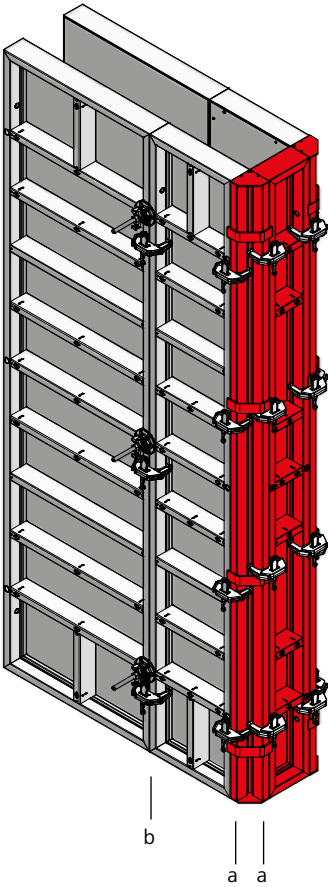

Fig. 44.1 Height 330 cm

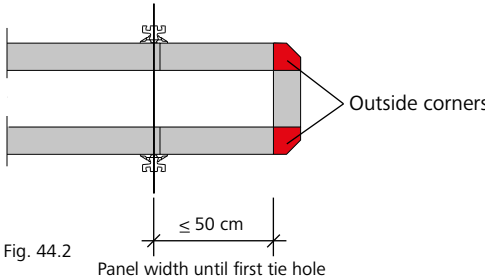

Fig. 44.2

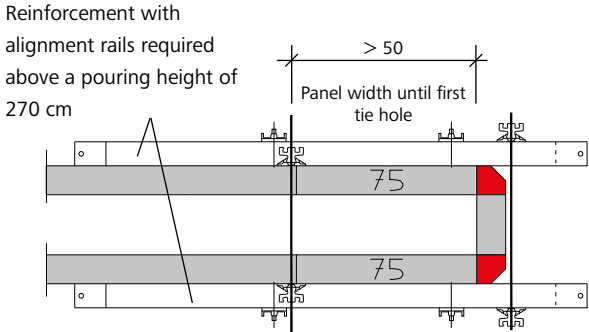

Fig. 44.3

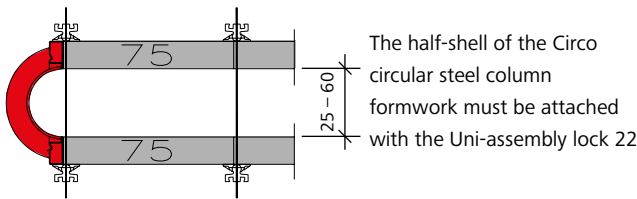

Fig. 44.4

Description	Ref. No.
AS/ST outside corner 330.....	22-140-10
AS/ST outside corner 270.....	22-140-20
AS/ST outside corner 135.....	22-140-30
AS/ST outside corner 90.....	22-140-40

Pouring height	Number of AS assembly locks	
	Corner (a)	Panel joint (b)
h = 0.90 m	2	2
h = 1.35 m	2	2
h = 2.70 m	3	2
h = 3.30 m	4	3
h = 4.05 m	5	4
h = 4.65 m	6	5
h = 5.40 m	6	5

Table 44.5

Wall Formwork

Stop ends

Stop end bracket

Stop ends can also be formed using the stop end bracket 23/40 for a wall thickness up to 30 cm or the stop end bracket 40/60 for a wall thickness up to 40 cm (Fig. 45.2).

When using a stop end bracket, there is no need to use a tie rod.

One stop end bracket is required per tie hole level (Fig. 45.1).

Stop end fixture and alignment rail

Another method of forming a stop end is to use two stop end fixtures 23/40, two flange nuts 100 and one alignment rail (Figures 45.3 and 45.4).

In addition, the panels must also be anchored on the outside. Two Uni-tie claws, one tie rod DW 15 and two flange nuts 100 are required for each additional tie connection (Figures 45.3 and 45.4).

One stop end fixture and one alignment rail plus the addition tie hole are used per tie hole level (Fig. 45.3).

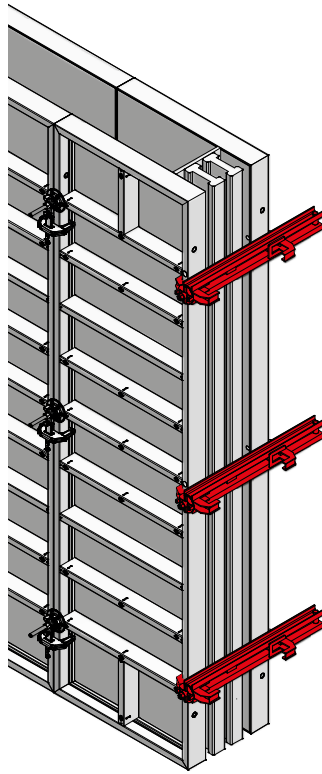

Fig. 45.1

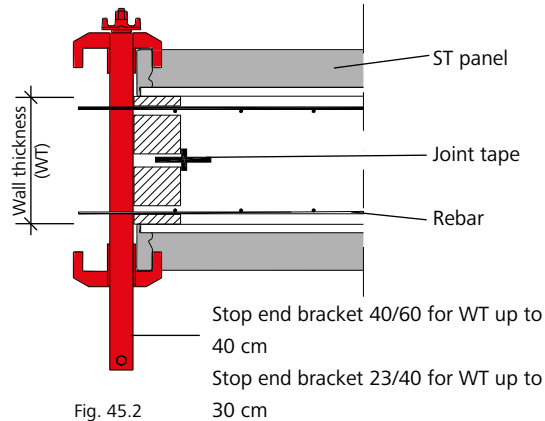

Fig. 45.2

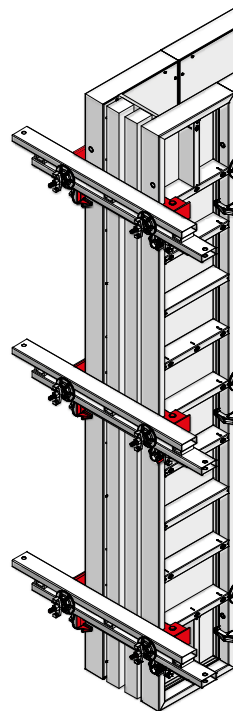

Fig. 45.3

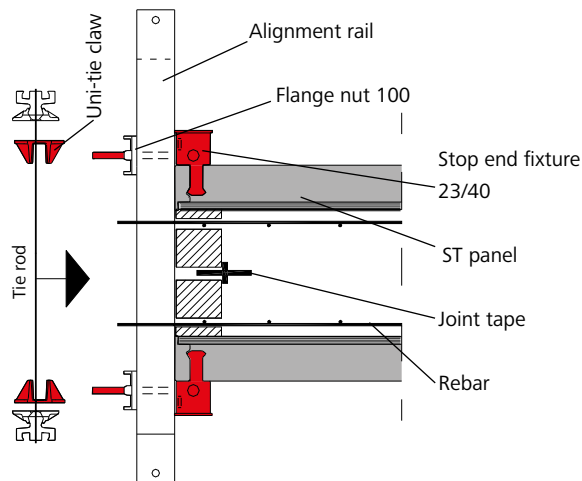

Fig. 45.4

Description	Ref. No.
Stop end fixture 23/40 yellow	79-402-85
Stop end bracket 40/60	29-105-50
Stop end bracket 23/40	29-105-45
Uni-tie claw	29-901-41
Uni-assembly lock 22	29-400-85
Flange nut 100	29-900-20
AS alignment rail 50	29-201-73
AS alignment rail 125	29-201-75

Wall Formwork

Wall offset

One-sided wall offsets of up to 10 cm are formed by moving back the corresponding standard panel (Figures 46.1 and 46.4).

For offsets greater than 13 cm inside corners should be used (Figures 46.2 and 46.5).

Wall offsets as depicted in Fig. 46.3 can be created using inside corners and M outside corner brackets.

All types of wall offset require alignment rails for reinforcement.

If the panels are offset as shown in Fig. 46.3, they can be connected with Uni-assembly locks (Fig. 46.5).

Tie rods of any length can be used to firmly bridge problem areas, e.g. pilasters, wall offsets, projecting building parts. They can be attached at all multi-function profiles irrespectively of the tie hole.

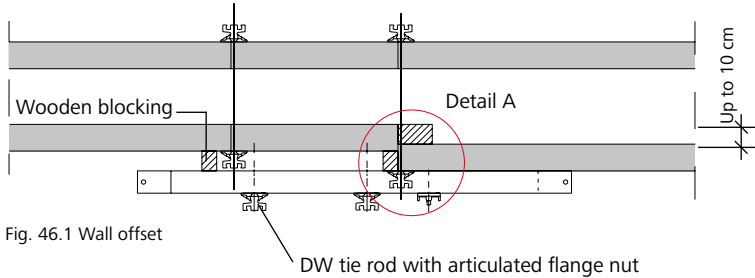

Fig. 46.1 Wall offset

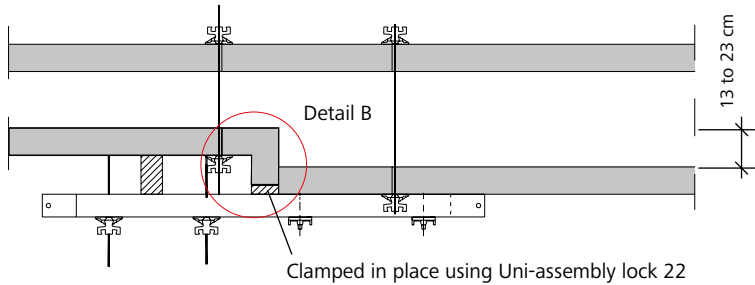

Fig. 46.2 Wall offset

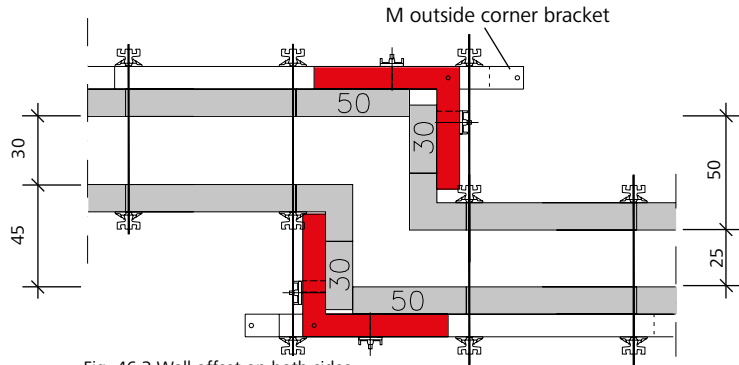

Fig. 46.3 Wall offset on both sides

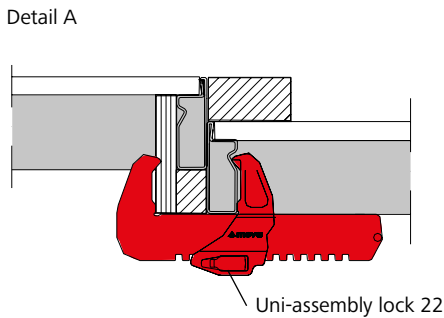

Fig. 46.4

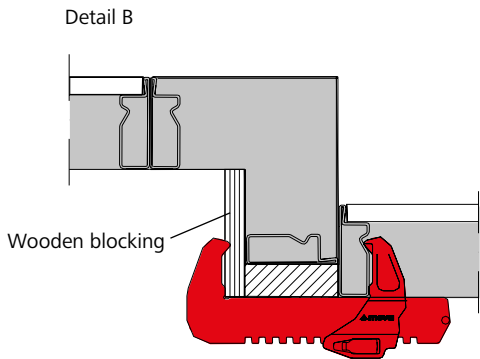

Fig. 46.5

Description	Ref. No.
M outside corner bracket.....	23-137-63
Uni-assembly lock 22	29-400-85

Pilasters

Standard pilasters are easily formed with inside corners, standard panels and, where necessary, wooden blockings. Alignment rails must be attached for reinforcement (Figures 47.1 to 47.3).

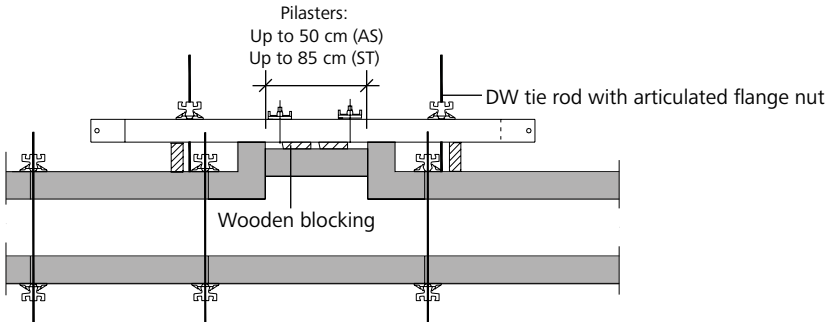

Fig. 47.1

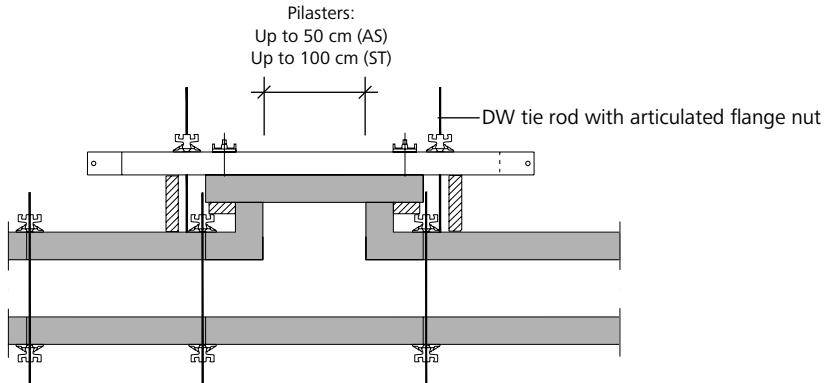

Fig. 47.2

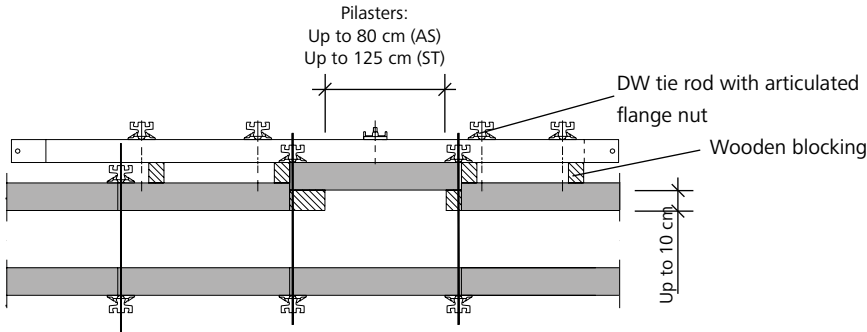

Fig. 47.3

Differences in height

The assembly lock can be attached at any position on the frame profile. The formwork's grid-free design does not require additional accessories for panel connection. Vertical, horizontal and inclined panels can all be safely and firmly connected with AS assembly locks, even with differences in height (Fig. 48.1).

A job-built length compensation is produced using timber profiles and a facing cut to the size required or a wooden board. If required, use square timbers for reinforcing.

Square timbers and panels are simply connected to each other with AS assembly locks (Figures 48.1 and 48.2).

Pay special attention when using wood fillers (see page ST/AS-41). It may be necessary to use alignment rails and/or wooden blockings.

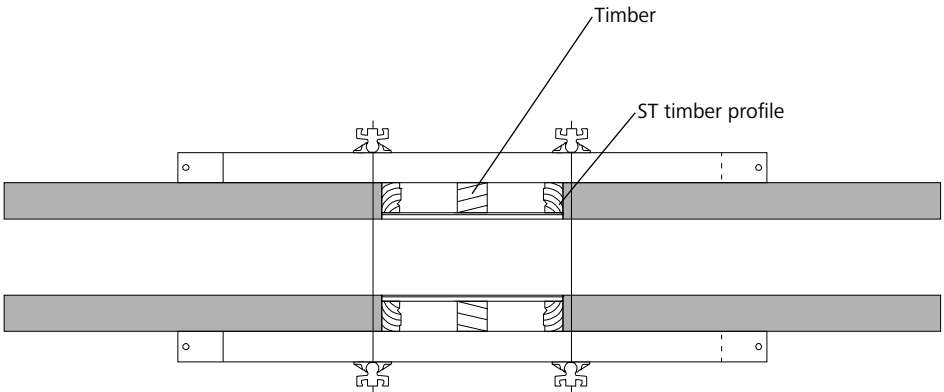
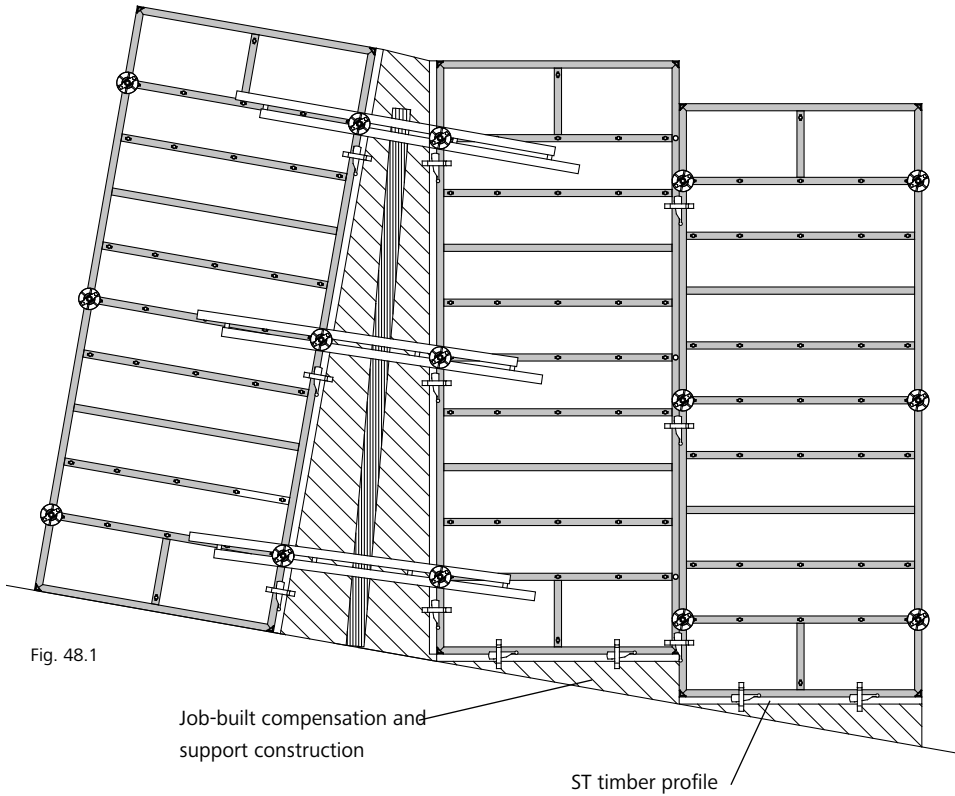

Wall Formwork

Horizontal panels

A lot of forming problems can easily be solved by arranging panels horizontally. These include basin walls in water treatment plants, foundations and strip footings which often require a certain height. The central tie hole makes the 135 cm wide StarTec and AluStar panels ideal for foundations.

When using foundation tapes and AS/ST tensioners (Figures 49.1 to 49.3), there is no need to put tie rods through the lower tie holes, which is very time-consuming. The AS/ST tensioner for foundation tape is clamped to the panel.

The top tie in the concrete can be replaced as follows:

→ Push-pull strut
This firmly connects the opposite panels up to a wall or foundation thickness of 60 cm (Fig. 49.2).

→ Uni-tie claw
Two Uni-tie claws, one tie rod DW 15 and two flange nuts 100 are required per tie connection (Figures 49.3 and 49.4). We recommend using a plastic tube D22, as it serves as a spacer and protects the tie rod against dirt.

The purpose of the compensation plate 12 (55 x 55) is to compensate for gaps between foundation formwork with a maximum foundation formwork height of 55 cm (Fig. 49.6). The maximum compensation width is 55 cm.

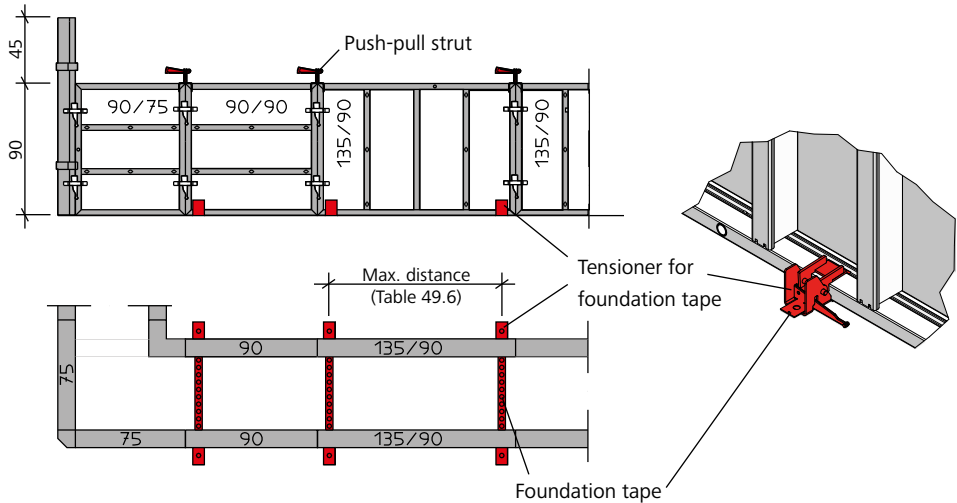

Fig. 49.1

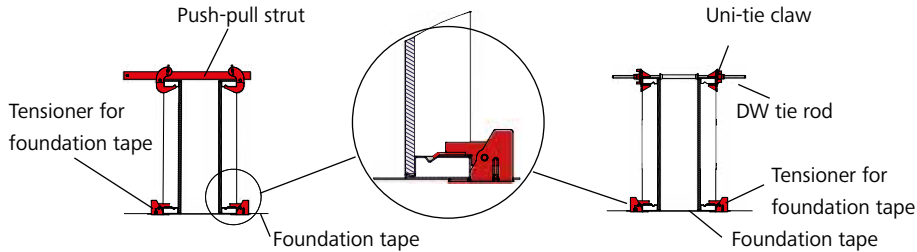

Fig. 49.2

Fig. 49.3

Maximum tensioner spacing	
Pouring height 75 cm	185 cm
Pouring height 100 cm	120 cm
Pouring height 135 cm	70 cm

Table 49.5

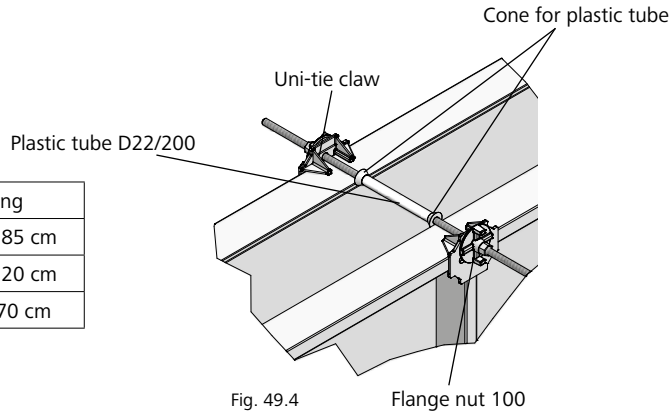

Fig. 49.4

Flange nut 100

Description	Ref. No.
Push-pull strut	29-105-70
Uni-tie claw	29-901-41
Foundation tape	29-307-50
Tensioner AS/ST for foundation tape	29-307-70
Trolley for foundation tape	29-307-55
Plastic tube D22/200	29-902-30
Cone for plastic tube D22/10	29-902-40
Cone for plastic tube D22/30	29-902-50
Plug D22	29-902-70
Compensation plate 12	29-201-17
Brace bracket 80	29-921-35
Flange screw 12	29-900-70

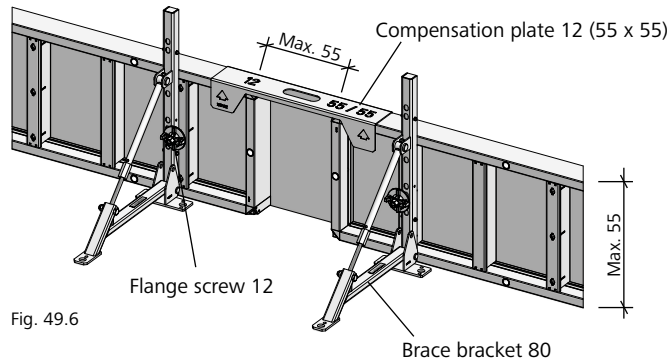

Fig. 49.6

Flange screw 12

Brace bracket 80

Wall Formwork

Substitution of ties

In certain cases alignment rails can reduce the number of tie rods required.

When extending a horizontal StarTec panel 270/240 with a horizontal panel 270/90 and by placing three alignment rails on the multi-function profile, the alignment rails substitute one row of ties (Fig. 50.1).

Compensation areas are reinforced with alignment rails. Thus, it is not necessary to use the tie holes in the filler. The length of the filler is determined by the following factors:

- The panel – StarTec or AluStar
- The type of alignment rail used
- The location of the alignment rail – at tie hole level or on the multi-function profile.

For perfect alignment we recommend attaching the alignment rails to the multi-function profile and limiting the filler width to half the length of the alignment rails. (Fig. 50.2 and Table 50.3).

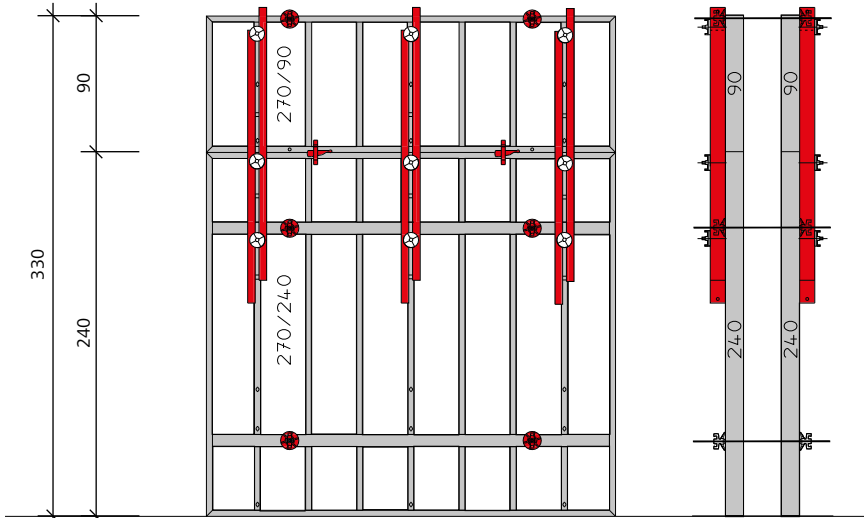

Fig. 50.1

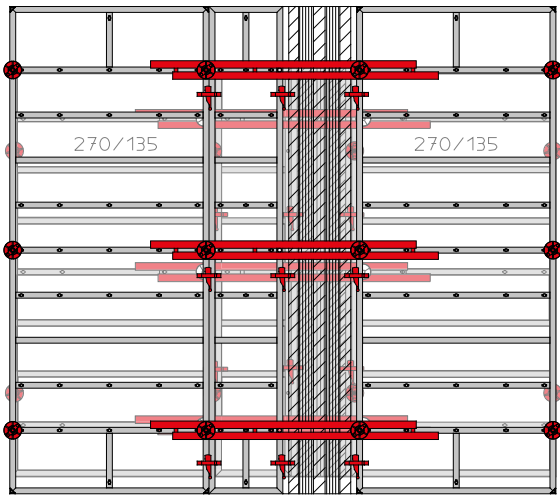

Fig. 50.2

If the fresh-concrete pressure is $P_{bmax} = 60 \text{ kN/m}^2$ and if lines 5 and 6 of DIN 18202 are observed (see page ST/AS-15), the following filler widths (cm) can be bridged:

Alignment rail	Filler width at tie hole level	Filler width on multi-function profile
AS-RS 50	35	25
AS-RS 125	70	70
AS-RS 200	80	80
M-RS 180	80	100
M-RS 250	80	110
M-RS 450	125	175

Table 50.3

Description	Ref. No.
AS alignment rail 50	29-201-73
AS alignment rail 125	29-201-75
AS alignment rail 200	29-201-80
M alignment rail 180	29-400-92
M alignment rail 250	29-402-50
M alignment rail 450	29-402-40
M alignment rail 350 reinforced	29-402-45
M alignment rail 450 reinforced	29-402-38

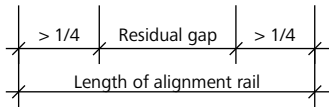

Height extension

Note the following for horizontal height extension

→ Tie rods must be used for all tie holes for a height extension with a panel that is wider than 50 cm (Fig. 51.1).

→ Only the top ties need to be used if the height is extended with a panel that has a width greater than 30 cm and up to 50 cm (Fig. 51.2).

→ For a height extension with a panel that is up to 30 cm wide, it is not necessary to install ties in the tie holes of the height-extended panel as long as the scaffolding bracket is attached to the panel below. However, if the scaffolding bracket is attached to the top panel, it is necessary to install ties in the top tie holes. The Uni-tie claw in conjunction with a tie rod and a flange nut 100 can also be used to tie this configuration.

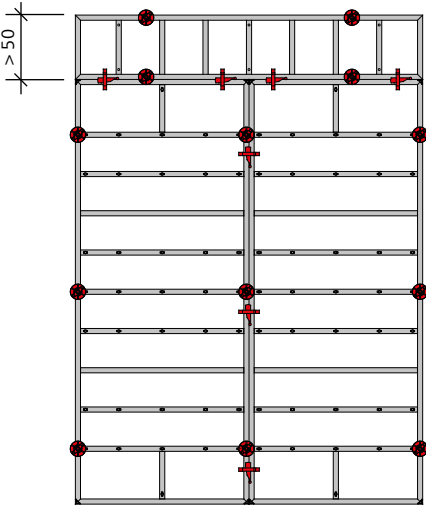

Fig. 51.1

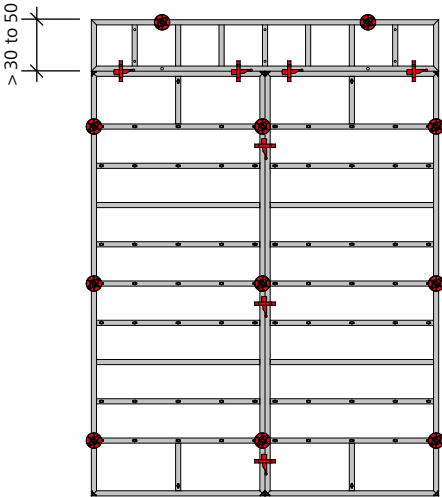

Fig. 51.2

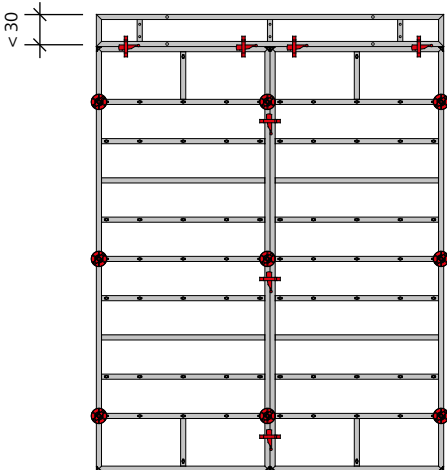

Fig. 51.3

Height extension

Free combination of vertical and horizontal panels

All panels can be height-extended vertically or horizontally. The standard panels are 330, 270, 135 and 90 cm (StarTec) high. This results in maximum height increments of 45 cm.

Using horizontal panels, almost any formwork height can be achieved. The large-size panel 270/240 cm (StarTec) is used horizontally when extending the formwork height.

They must always be connected with the AS assembly lock (see page ST/AS-12).

→ Alignment rails are required for height extensions to stabilise the panels (refer to Table 53.3).

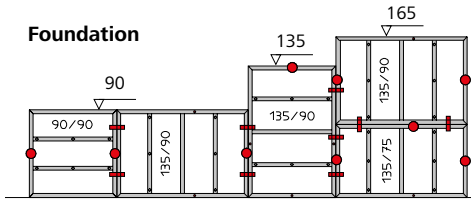

Fig. 52.1

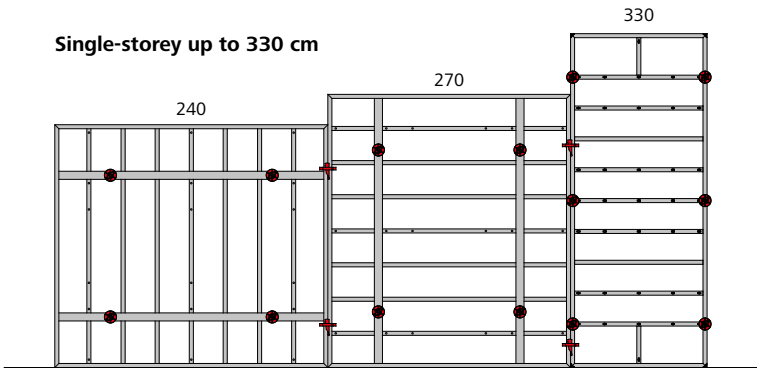

Fig. 52.2

Height-extended above 270 cm

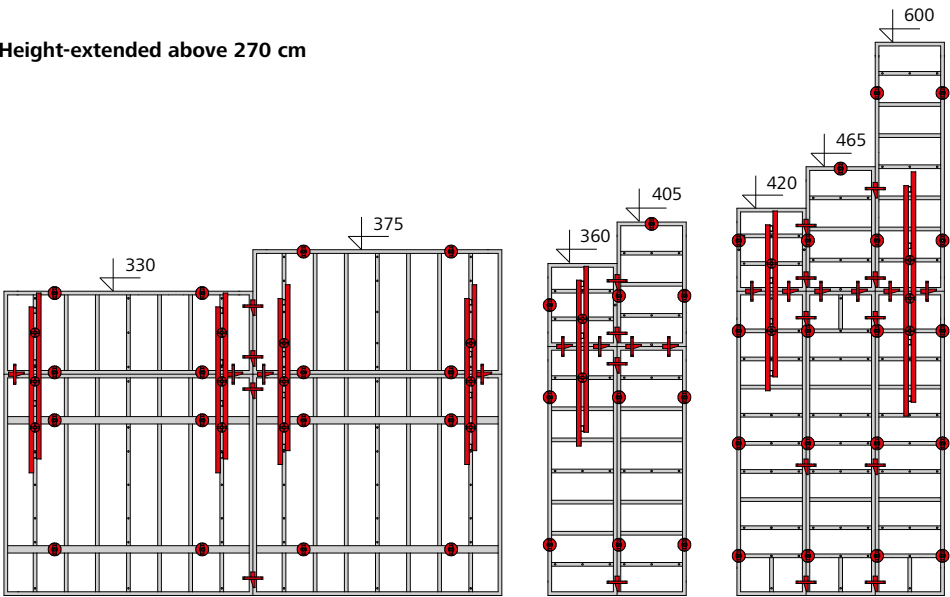

Fig. 52.3

Height extension

Free combination of vertical and horizontal panels

All panels can be height-extended vertically or horizontally. They must always be connected with the AS assembly lock (see page ST/AS-12).

→ Alignment rails are required for height extensions to stabilise the panels (Table 53.3). For heights above 8.10 m please contact our application engineering department. The total weight of the height-extended unit depends on the load capacity of the crane hook (see page ST/AS-24).

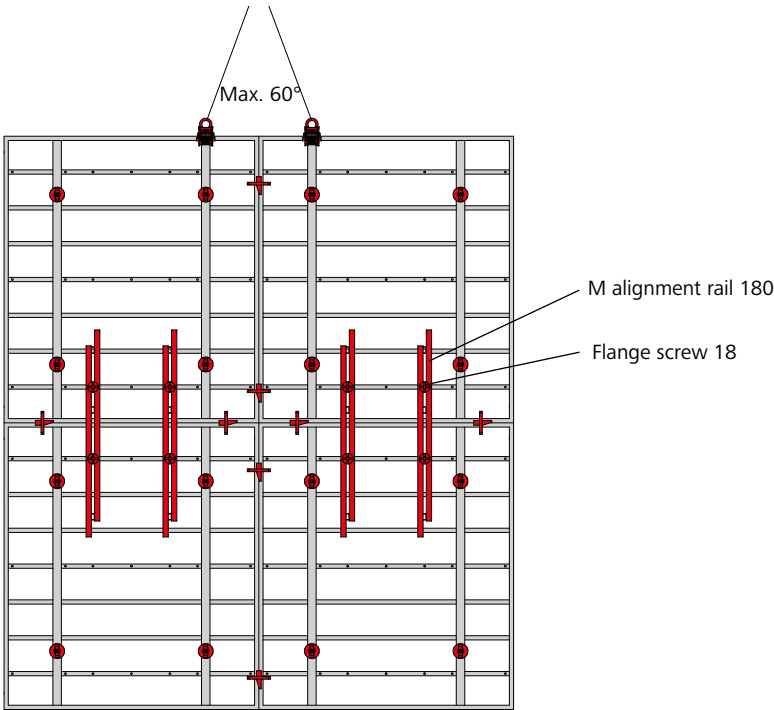

Fig. 53.1

Vertical or horizontal extension

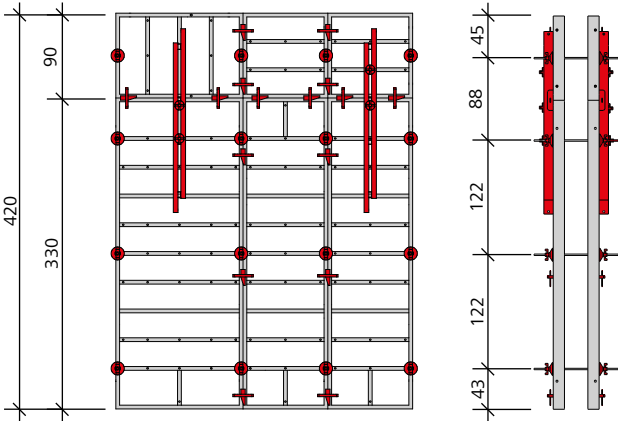

Fig. 53.2

Formwork height	Alignment rail for each horizontal joint for a width of 1.35 m	
	Alignment rail	Quantity
Up to 5.40 m	M 180	1
Up to 8.10 m	M 250	1

Table 53.3

Description	Ref. No.
M alignment rail 180	29-400-92
M alignment rail 250	29-402-50
Flange screw 18.....	29-401-10

Crane ganging

When crane-ganging panels, always check whether the crane hook is attached to an aluminium cross stiffener or a steel cross stiffener, as this will determine how you have to lift the panels. The panels' year of manufacture can also play a role when transporting by crane. Methods 1 to 5 on pages ST/AS-55 to -59 show how to lift and crane-gang the various panels. This may reduce the AS crane hook's maximum load capacity of 15 kN.

For a general description and notes on how to use the AS crane hook refer to page ST/AS-24.

The StarTec panels 270/90 and 270/75 produced until 2006 are equipped with aluminium and steel cross stiffeners (Fig. 54.1), whereas StarTec panels produced since 2006 have only steel cross stiffeners (Fig. 54.2).

Aluminium cross stiffeners can be identified by their grip profiles, whereas steel cross stiffeners do not have grip profiles (Figures 54.3 and 54.4).

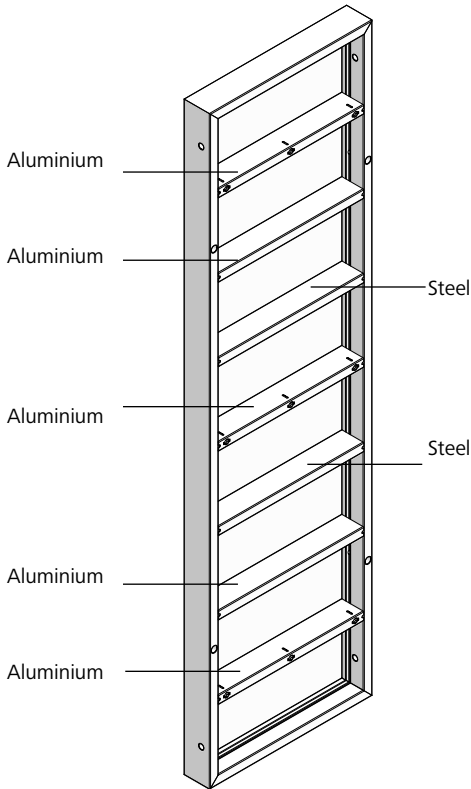

Fig. 54.1
StarTec panel 270/90
and 270/75 built until 2006

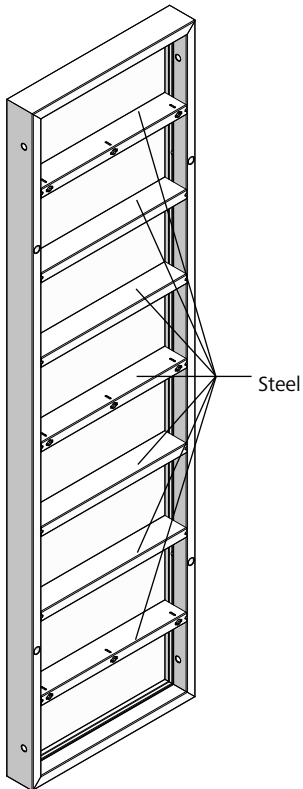

Fig. 54.2
StarTec panel 270/90
and 270/75 built from 2006

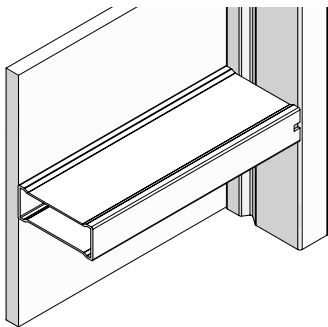

Fig. 54.3
Aluminium cross stiffener (with grip profile)

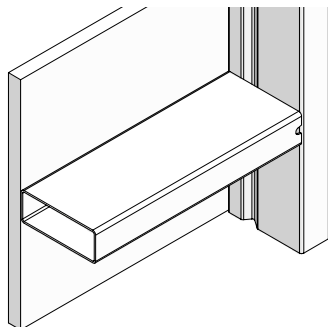

Fig. 54.4
Steel cross stiffener (without grip profile)

Crane ganging – Method 1

Use this method for single vertical AluStar and StarTec panels or vertical panel gangs irrespective of the year of manufacture (Fig. 55.1).

The crane hook's load capacity is 15 kN (1.5 tons).

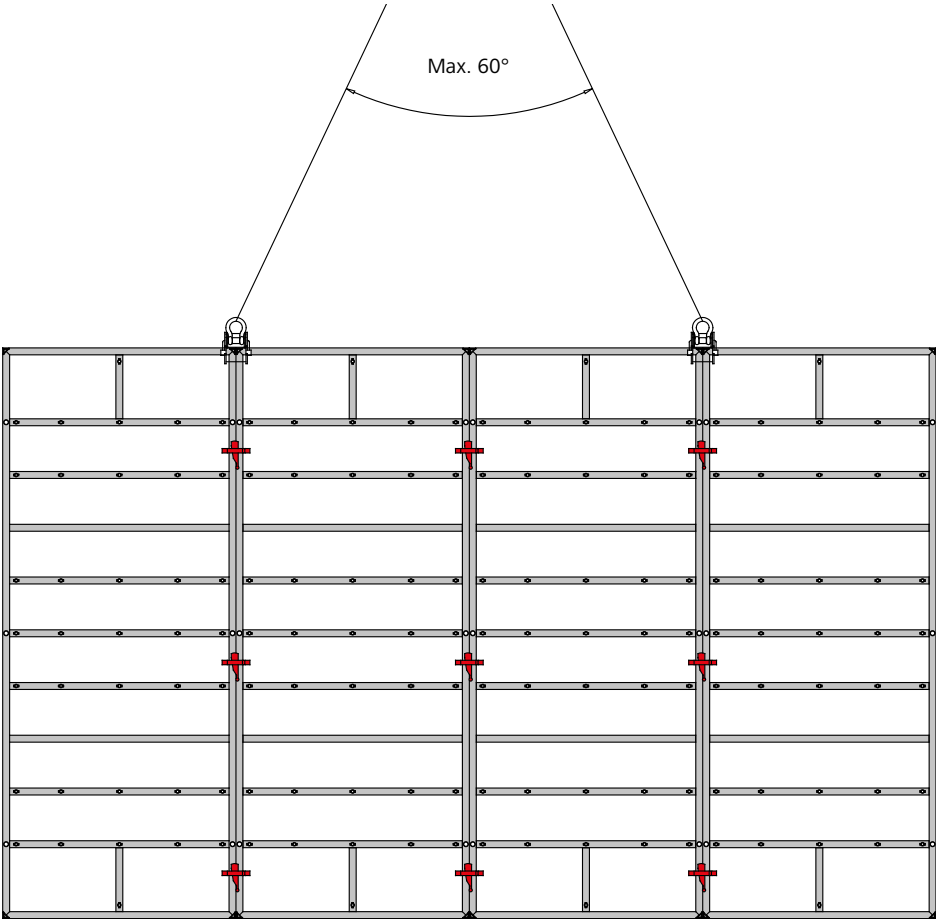

Fig. 55.1

Crane ganging – Method 2

Use this method for single horizontal panels or for units height-extended with horizontal panels when using StarTec panels manufactured in 2006 or later (Fig. 56.1).

The crane hook's load capacity is 15 kN (1.5 tons).

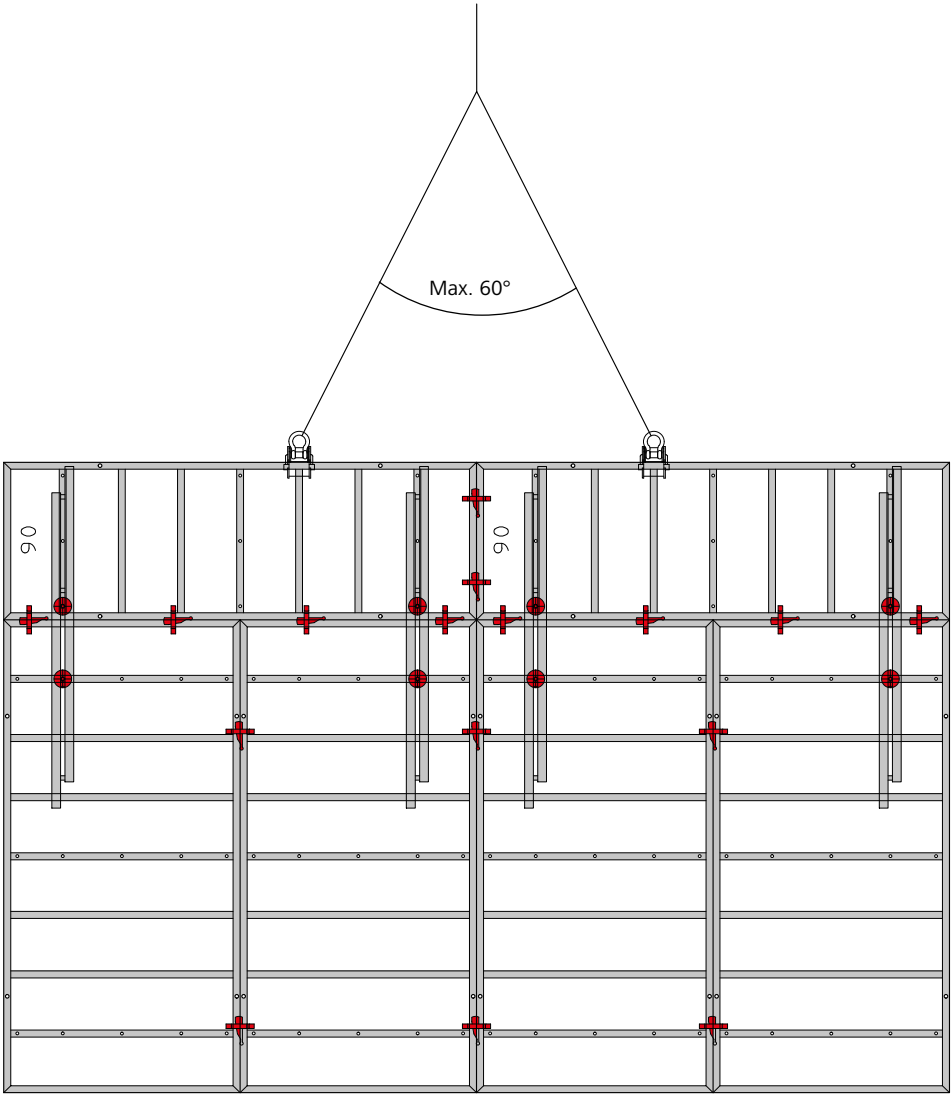

Fig. 56.1

Crane ganging – Method 3

Use this method for single horizontal panels (Figures 57.1 and 57.2) or for units height-extended with horizontal panels (Fig. 57.3) if these are StarTec panels 270/90 or 270/75 manufactured up to 2006.

The crane hook's load capacity is 15 kN (1.5 tons).

Note that the AS crane hooks must be attached to the 3rd and 5th cross stiffeners which are both made of steel (Figures 57.1 to 57.3 and page ST/AS-54).

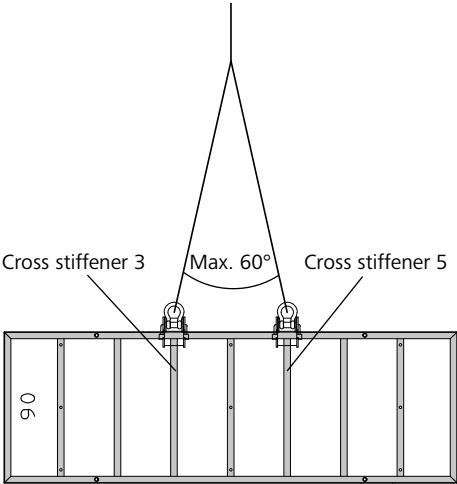

Fig. 57.1
StarTec panel 270/90

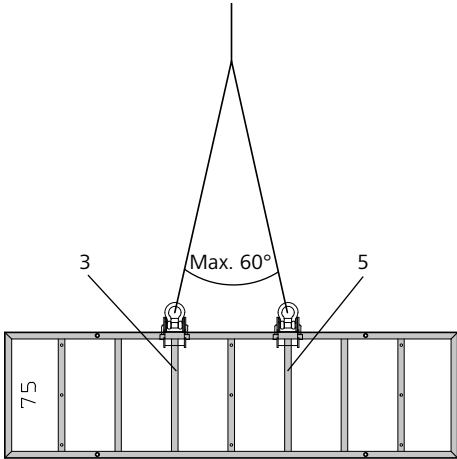

Fig. 57.2
StarTec panel 270/75

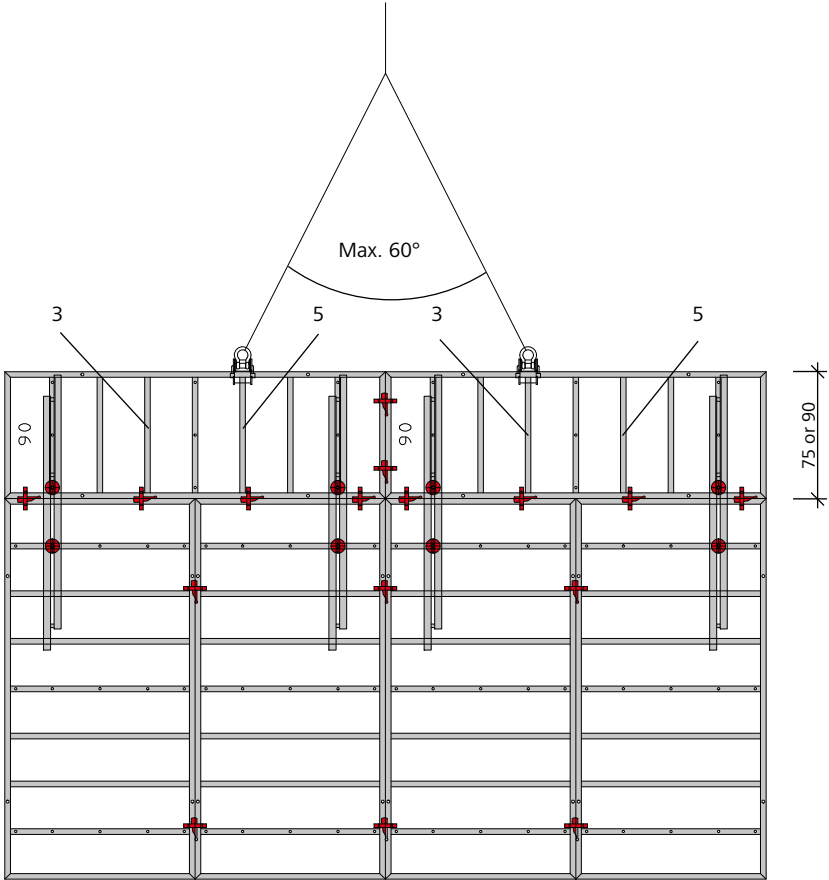

Fig. 57.3
Height extension with horizontal StarTec panels 270/90 or 270/75

Crane ganging – Method 4

Use this method for single horizontal panels (Figures 58.1 and 58.2) or for units height-extended with horizontal panels (Fig. 58.3) if these are StarTec panels 270/90 or 270/75 manufactured up to 2006.

The crane hooks may be attached to any cross stiffener but the load capacity of each crane hook is reduced to 9 kN (0.9 tons).

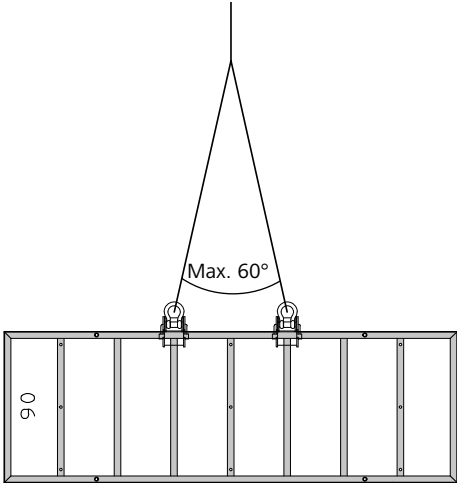

Fig. 58.1
StarTec panel 270/90

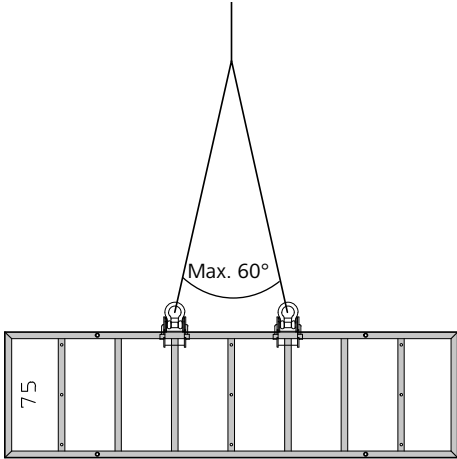

Fig. 58.2
StarTec panel 270/75

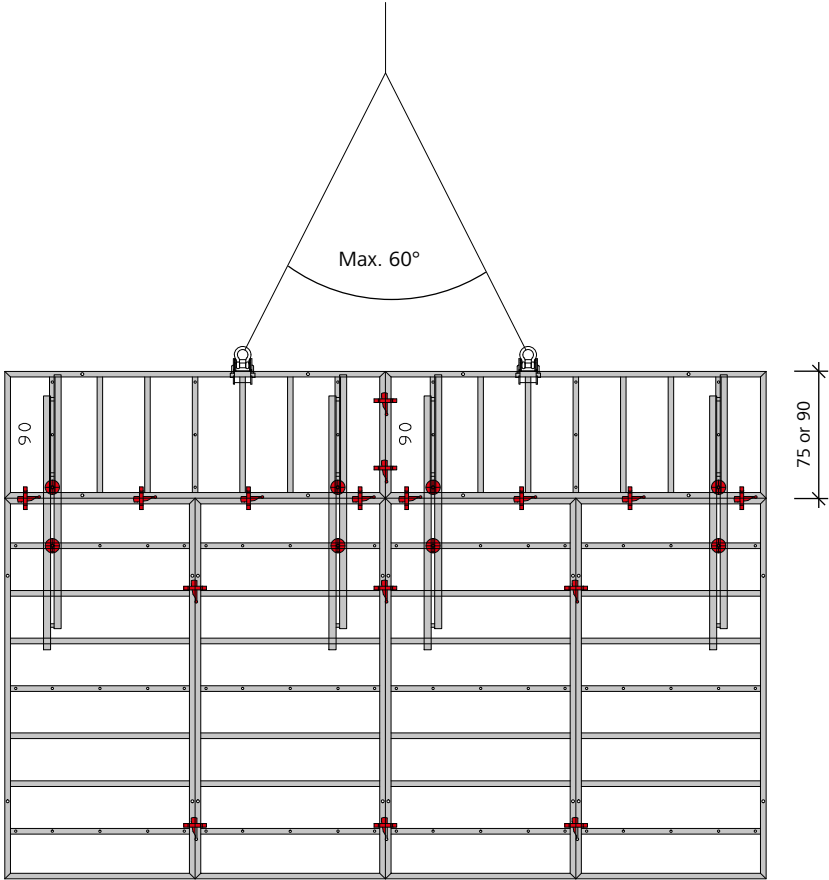

Fig. 58.3
Height extension with horizontal StarTec panels 270/90 or 270/75

Crane ganging – Method 5

Use this method for single horizontal panels (Fig. 59.1) or for units height-extended with horizontal panels (Fig. 59.2) if these are AluStar or StarTec panels.

The crane hooks may be attached to any cross stiffener but the load capacity of each crane hook is reduced to 11 kN (1.1 tons).

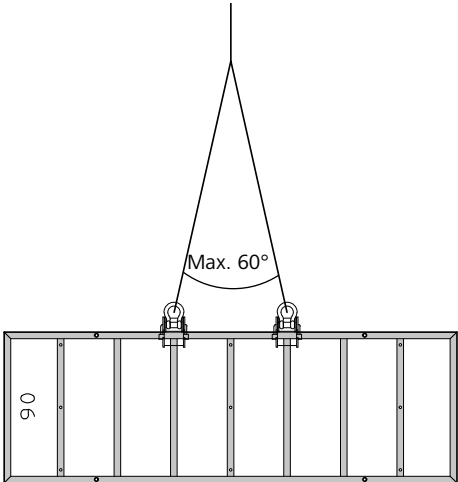

Fig. 59.1
AluStar panel 270/90

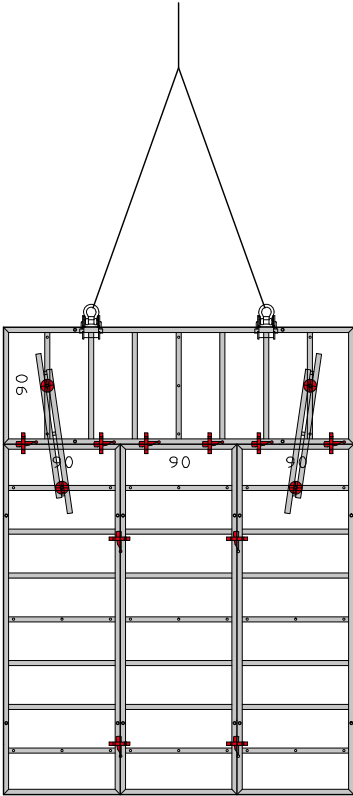

Fig. 59.2
AluStar or StarTec unit, height-extended with horizontal AluStar panel 270/90

Crane ganging

Each transport unit requires two AS crane hooks with a load capacity of 15 kN (1.5 tons) attached symmetrically to the centre of gravity! The load-bearing capacity of 15 kN (1.5 tons) may be reduced depending on whether the panels are lifted vertically or horizontally, whether the cross stiffeners are made of aluminium or steel and depending on the year of manufacture of the panels (see page ST/AS-54).

When the panels are horizontal, the crane hook must be attached to a cross stiffener to prevent it from slipping (Figures 60.1 and 60.2).

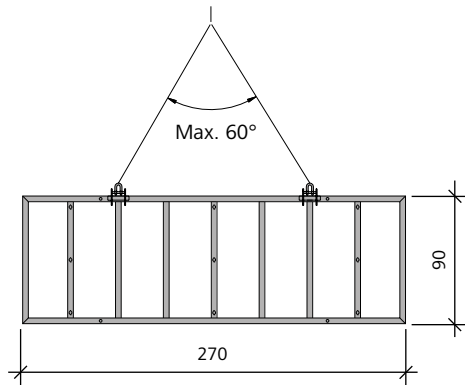

Fig. 60.1
AluStar/StarTec

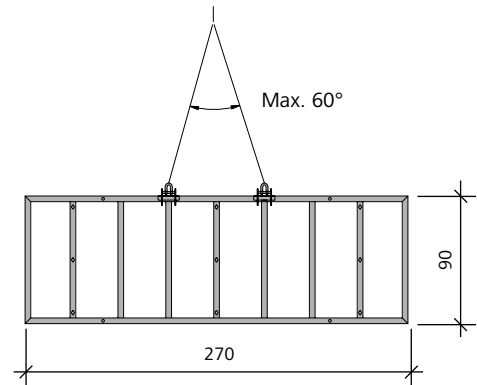

Fig. 60.2
AluStar/StarTec

In order to provide the necessary flexural rigidity when lifting and laying down gangs, alignment rails must be mounted to the panels with flange screws (Fig. 60.3).

Figures 60.1 and 60.2

Panel unit with alkus all-plastic facing. Size:

2.70 x 0.90 m = 2.43 m²

Weight:

AluStar = 65.0 kg

StarTec = 103.4 kg

Fig. 60.3

StarTec panel unit with alkus all-plastic facing. Size:

5.40 x 4.65 m = 25.11 m².

Weight including four alignment rails 180 = 1605 kg.

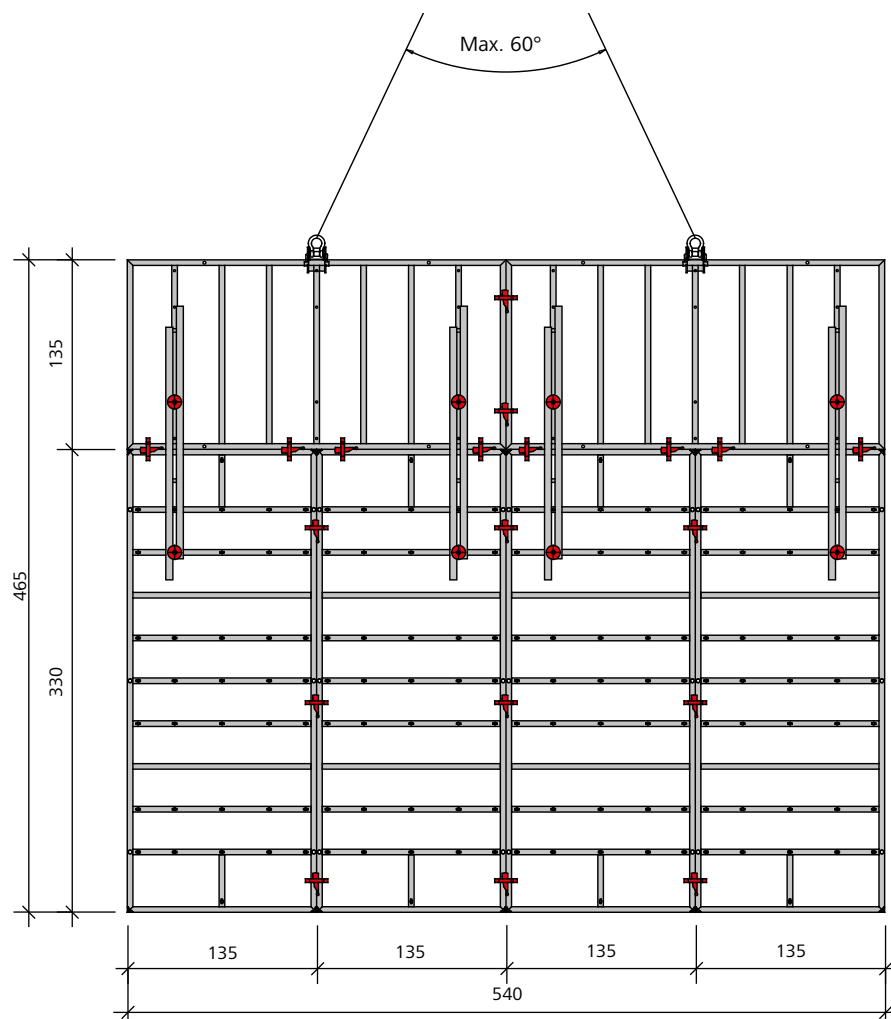

Fig. 60.3

Crane ganging

Fig. 61.1

StarTec panel unit with alkuS all-plastic facing. Size: 5.40 x 3.30 m = 17.82 m²
Weight: 1065 kg.

Fig. 61.2

StarTec panel unit with alkuS all-plastic facing. Size: 5.40 x 6.60 m = 35.64 m².
Weight including four alignment rails 180 = 2250 kg.

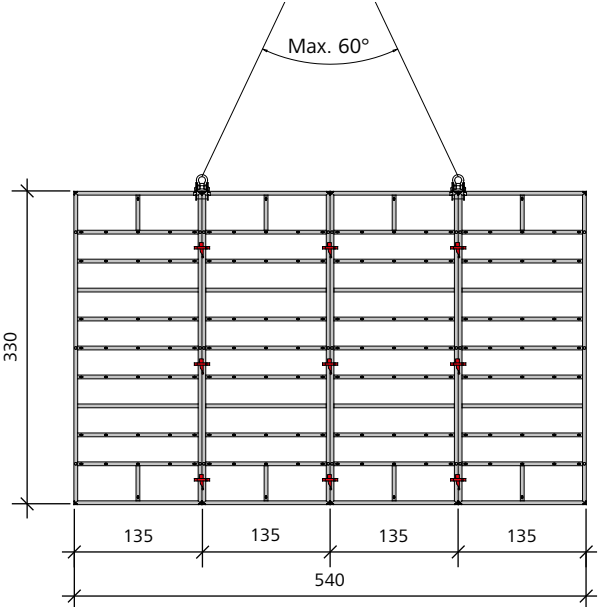

Fig. 61.1

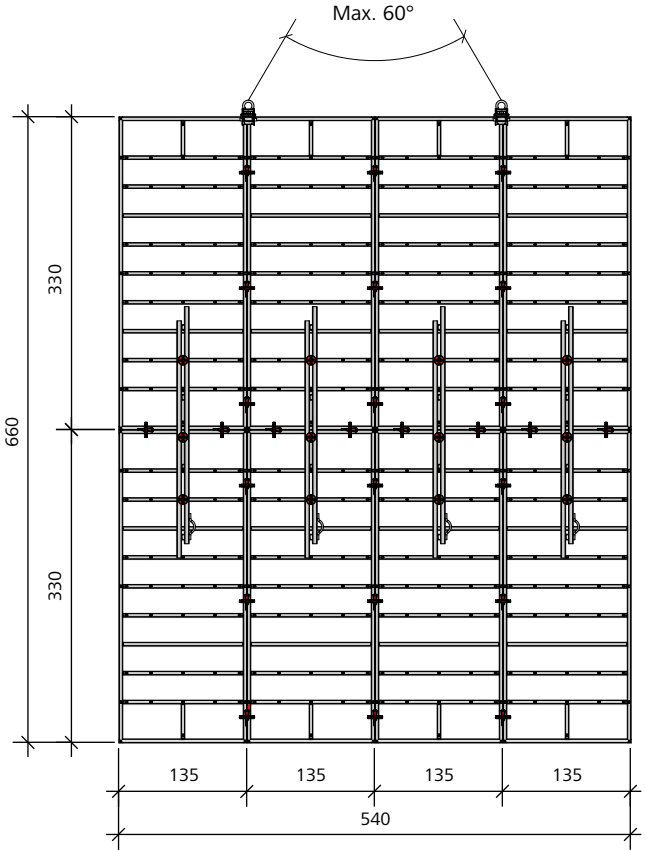

Fig. 61.2

StarTec column formwork

Columns with a maximum side length of 50 cm and a maximum pouring height of 495 cm can be formed using standard panels and outside corners.

For the number of assembly locks required refer to Table 62.1.

The higher fresh-concrete pressure resulting from high columns or from longer side lengths means that additional alignment rails are required for reinforcement (Table 62.1). The alignment rails must be attached to the multi-function profiles on all four sides of the panels with two flange screws 18. Always install the alignment rails starting with the lowermost multi-function profile level (Figures 62.6 to 62.8). Also observe DIN 18218 for fresh-concrete pressure and DIN 4235 for compacting concrete with a vibrator.

When pouring foundations, two assembly locks are required for a foundation with a maximum side length of 135 cm and a maximum height of 135 cm.

ST column formwork					
Formwork height h [cm]	Number of alignment rails (from bottom to top)				Number of AS assembly locks
	Column side length [cm]				
	Up to 50	75	90	135	
135	-	-	-	-	2
270	-	-	-	-	4
330	-	-	-	-	6
270 + 135 = 405	-	1	1	1	(5 + 2) = 7
270 + 135 + 90 = 495	-	1	1	1	(5 + 2 + 2) = 9
270 + 270 = 540	1	1	1	1	(5 + 5) = 10
330 + 270 = 600	1	1	1	2	(6 + 5) = 11
270 + 270 + 90 = 630	1	1	2	2	(5 + 5 + 2) = 12
330 + 330 = 660	1	2	3	3	(6 + 6) = 12
270 + 270 + 135 = 675	1	2	2	3	(5 + 5 + 2) = 12
270 + 270 + 270 = 810	2	3	3	4	(5 + 5 + 5) = 15

Table 62.1

Number of assembly locks required for the horizontal joints of all standard panels:

- Four AS assembly locks for panel width 135 cm
- Three AS assembly locks for panel width 90 cm
- Two AS assembly locks for a panel width less than 90 cm

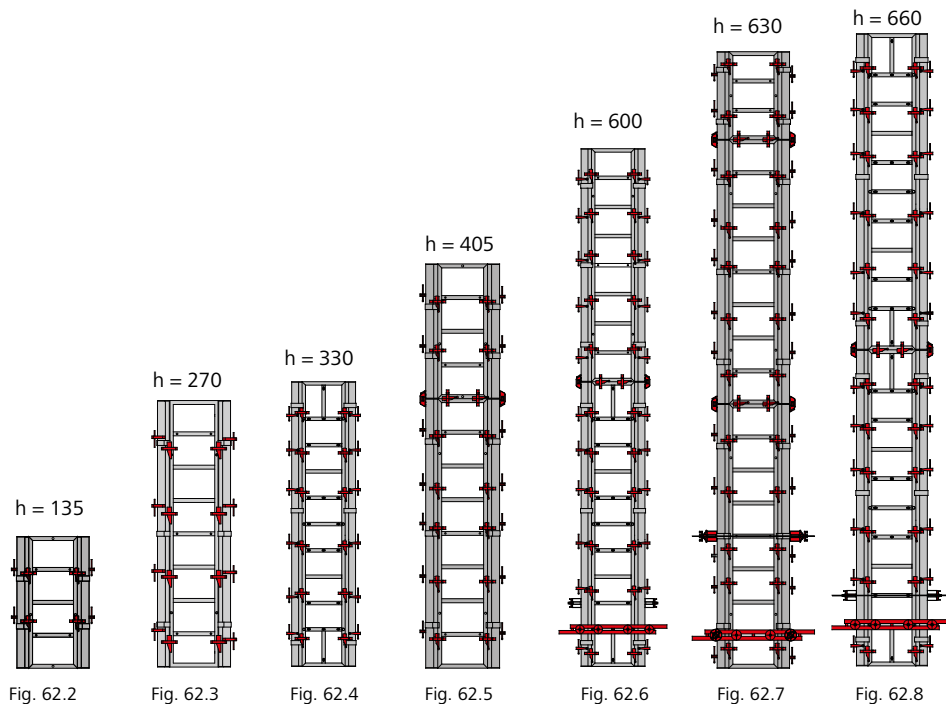

Description	Ref. No.
AS/ST outside corner 330.....	22-140-10
AS/ST outside corner 270.....	22-140-20
AS/ST outside corner 135.....	22-140-30
AS/ST outside corner 90.....	22-140-40

AluStar column formwork

Columns with a maximum side length of 50 cm and a maximum pouring height of 405 cm can be formed using standard panels and outside corners.

Three assembly locks are sufficient for a formwork height up to 270 cm (Fig. 63.3).

A pouring height of 405 cm (270 and 135 cm panels) requires five assembly locks for the 270 cm panel and two assembly locks for all other panels (Fig. 63.4).

The higher fresh-concrete pressure resulting from high columns or from longer side lengths means that additional alignment rails are required for reinforcement (Table 63.1). Each alignment rail must be attached to the panel with two flange nuts 18. Ensure that alignment rails are attached to all multi-function profiles all around the column, starting at the lowest multi-function profile (Fig. 63.5). Also observe DIN 18218 for fresh-concrete pressure and DIN 4235 for compacting concrete with a vibrator.

When pouring foundations, two assembly locks are required for a foundation with a maximum side length of 135 cm and a maximum height of 90 cm or vice versa.

AluStar column formwork					
Formwork height h [cm]	Number of alignment rails (from bottom to top)				Number of AS assembly locks
	Column side length [cm]				
	25	30 – 50	75	90	
135	-	-	-	-	2
270	-	-	-	-	4
270 + 135 = 405	-	-	1	1	(5 + 2) = 7
270 + 135 + 90 = 495	1	1	1	1	(5 + 2 + 2) = 9
270 + 270 = 540	1	1	1	1	(5 + 5) = 10
270 + 270 + 90 = 630	1	1	2	2	(5 + 5 + 2) = 12
270 + 270 + 135 = 675	2	2	3	3	(5 + 5 + 2) = 12
270 + 270 + 270 = 810	2	3	4	4	(5 + 5 + 5) = 15

Table 63.1

Number of assembly locks required for the horizontal joints of all standard panels:

- Four AS assembly locks for panel width 135 cm
- Three AS assembly locks for panel width 90 cm
- Two AS assembly locks for a panel width less than 90 cm

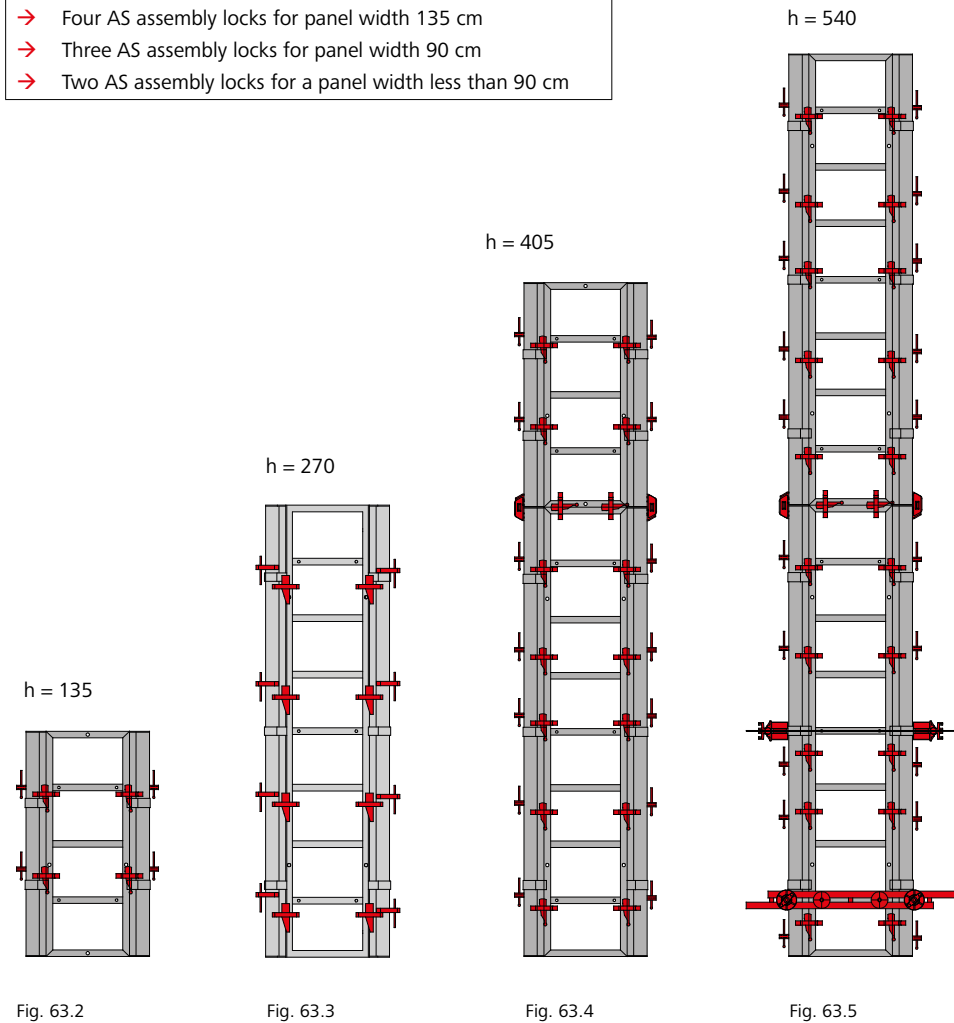

Multi-purpose panel

Multi-purpose panels (MPP) are used as column formwork, for wall connections (Fig. 64.1), pilasters (Fig. 64.2) and right-angled and oblique-angled corners (Fig. 64.3).

The multi-purpose panels are equipped with perforated profiles to attach the stop end fixtures, the tie rods and flange screws, see page ST/AS-65.1.

The 13 tie holes at tie hole level allow for a completely flexible use of the multi-purpose profiles when used for double-sided formwork (Fig. 64.1).

Fig. 64.3 If length X is smaller than L/2, no alignment rails are required on the outside.

Connection to existing walls

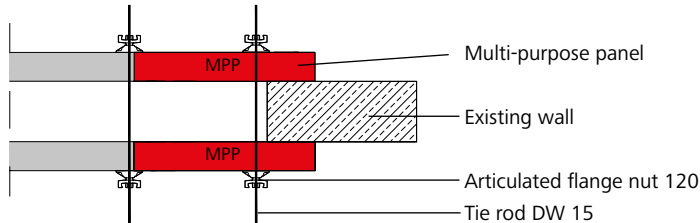

Fig. 64.1

Pilaster with < 29 cm wall thickness (WT)

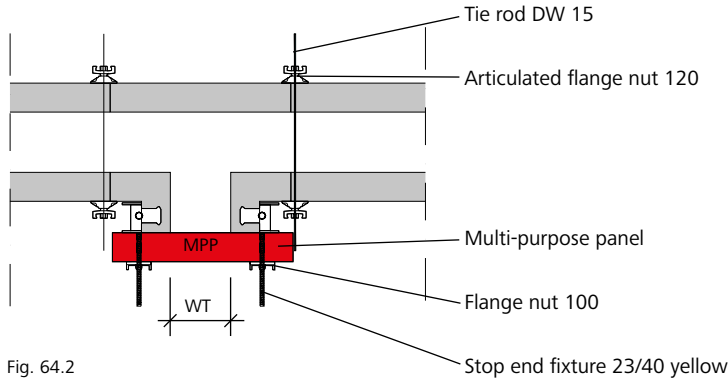

Fig. 64.2

Obtuse-angled corner

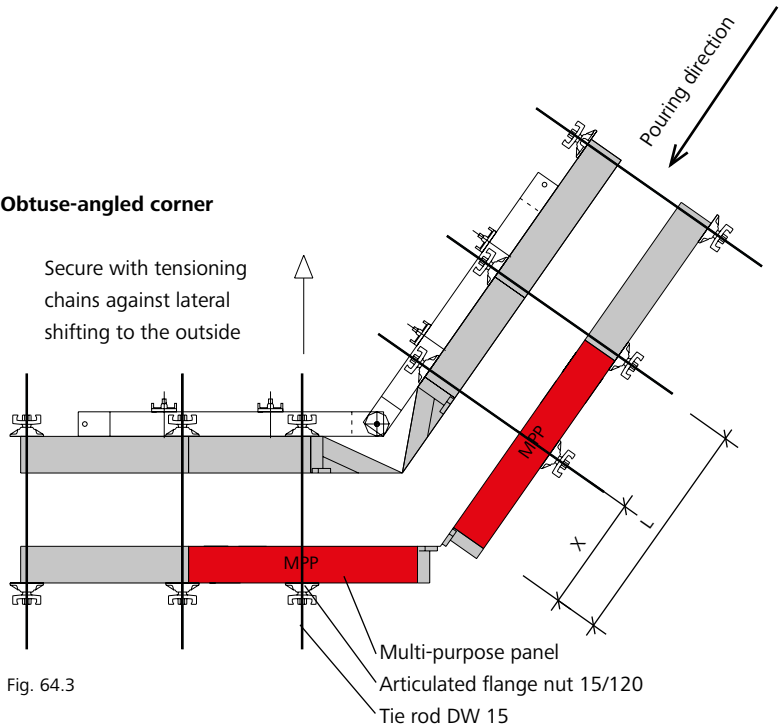

Fig. 64.3

Description	Ref. No.
Multi-purpose panel	
StarTec AL MPP 270/75.....	21-212-26
StarTec AL MPP 135/75.....	21-212-46
Stop end fixture 23/40.....	79-402-85
Flange screw 18.....	29-900-20
Articulated flange nut 15/120.....	29-900-10
Tie rod DW 15/90.....	29-900-80

Multi-purpose panel

The perforated profile (Fig. 65.1) permits exceedingly accurate forming of square and rectangular columns up to 60 cm, stop ends, pilasters up to a width of 29 cm, 90° corners and wall offsets up to 30 cm in all standard dimensions. Tying at the multi-adjustment profile is possible at 13 positions.

Further formwork dimensions can be achieved by turning the panels by 180° (Figures 65.2 and 65.3, Table 65.4).

Detailed view of the perforated profile

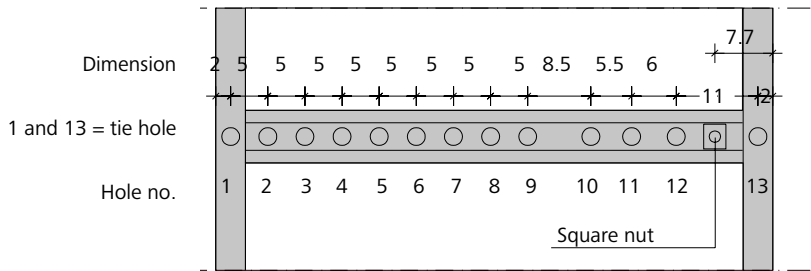

Fig. 65.1

Attention

When using the multi-purpose panel (MPP) for a column or corner application, the flange screw must never be used in hole no.1 and hole no. 13 (standard tie hole)!

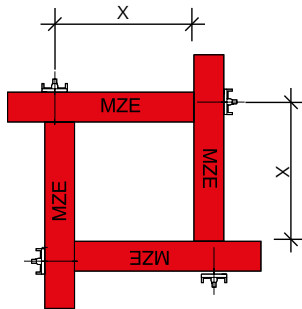

Fig. 65.2
Example A, counterclockwise

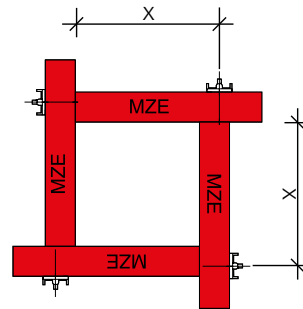

Fig. 65.3
Example B, clockwise

Tying overview for column and corner solutions with two or four multi-purpose panels

Hole no.	Column dimension x Windmill vane principle Example A	Dimension	Column dimension x Windmill vane principle Example B
2		68	60 x 60 cm
3		63	55 x 55 cm
4		58	50 x 50 cm
5		53	45 x 45 cm
6	19 x 19 cm	48	40 x 40 cm
7	24 x 24 cm	43	35 x 35 cm
8	29 x 29 cm	38	30 x 30 cm
9	34 x 34 cm	33	25 x 25 cm
10	42.5 x 42.5 cm	24.5	16.5 x 16.5 cm
11	48 x 48 cm	19	
12	54 x 54 cm	13	

Description	Ref. No.
Multi-purpose panel	
StarTec AL MPP 270/75.....	21-212-26
StarTec AL MPP 135/75.....	21-212-46

Table 65.4

Corner solutions with multi-purpose panels

This page shows how to form a 90° corner with two multi-purpose panels (MPP) 270/75 or 135/75 in a windmill vane arrangement. The multi-purpose panels are connected using the DW 15 threads in the side profile and flange screws.

The wall thickness can be formed in increments of 5 cm up to 35 cm when using multi-purpose panels. The flange screw connects the two multi-purpose panels solidly, tightly and at a right angle.

For the MPP 135/75 a single flange screw 18 is sufficient for the connection. For the MPP 270/75 three flange screws 18 are required.

Attention

When using the multi-purpose panel for a column or corner application, the flange screw must never be used in hole no. 1 and hole no. 13 (standard tie hole)!

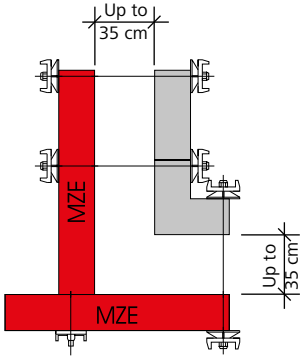

Fig. 66.1

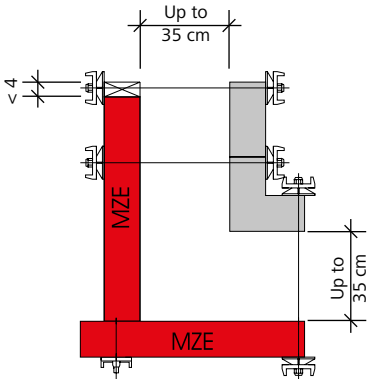

Fig. 66.2

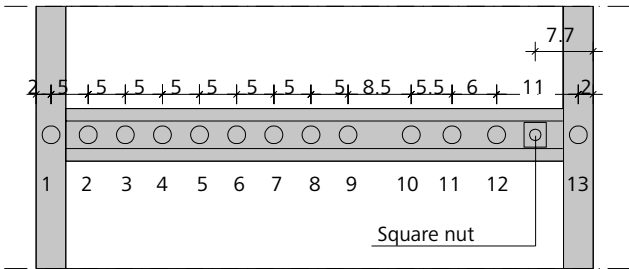

Fig. 66.3

Description	Ref. No.
Multi-purpose panel	
StarTec AL MPP 270/75.....	21-212-26
StarTec AL MPP 135/75.....	21-212-46

Corner solutions with multi-purpose panels

This page shows how to form a 90° corner with a multi-purpose panel 270/75 or 135/75 and a standard panel. The panels are connected using the stop end fixture 23/40 and the flange nut 100.

For the MPP 135/75 one stop end fixture 23/40 is sufficient for the connection. For the MPP 270/75 three stop end fixtures 23/40 are required.

Attention

When using the multi-purpose panel for a column or corner application, the stop end fixture must never be used in hole no. 1 and hole no. 13 (standard tie hole)!

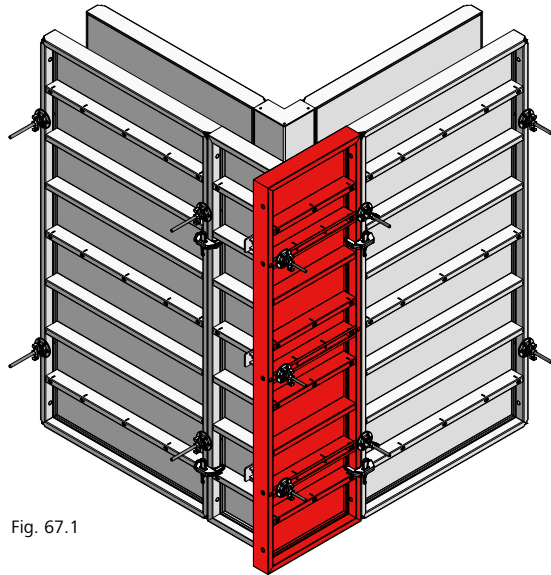

Fig. 67.1

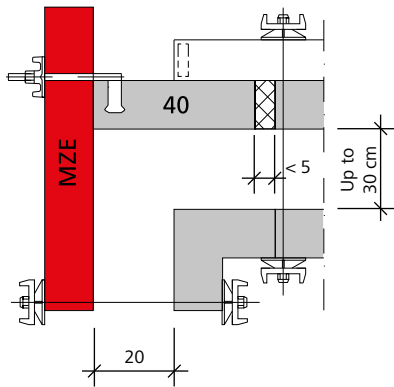

Fig. 67.2

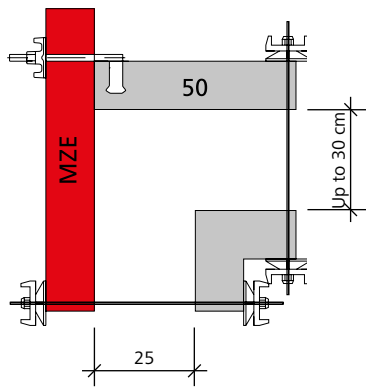

Fig. 67.3

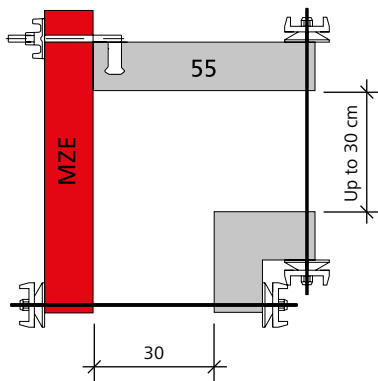

Fig. 67.4

Description	Ref. No.
Multi-purpose panel	
StarTec AL MPP 270/75.....	21-212-26
StarTec AL MPP 135/75.....	21-212-46
Stop end fixture 23/40.....	79-402-85
Flange nut 100.....	29-900-20

Panel with filling nozzle / concreting window

The ST panel AL 17 270/45 with a filling nozzle (Fig. 68.1) is used when concrete cannot be poured from above, e.g. in the case of tunnel formwork.

The manual gate valve SK (Fig. 68.2) prevents the concrete from flowing back when pumping is interrupted. It is attached to the filling nozzle with the lever coupling SK-H (Fig. 68.3).

After taking off the supply hose, the filling nozzle cleaner SK (Fig. 68.4) is attached to the manual gate valve with the lever coupling, the manual gate valve opened and the concrete pressed behind the forming face until it is flush with the front edge of the facing. One sealing washer A SK is required for each lever coupling.

The panel with concreting window (Fig. 68.6) has a covered 25 x 36 cm opening. This makes it possible to look behind the formwork. To do this, undo the four flange screws and remove the window cover.

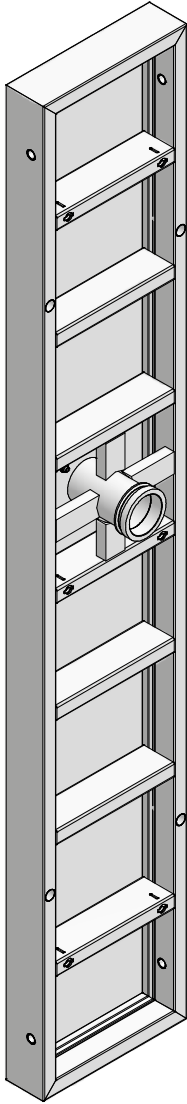

Fig. 68.1 Panel with filling nozzle

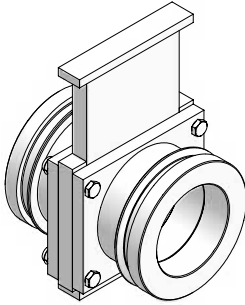

Fig. 68.2 Manual gate valve SK

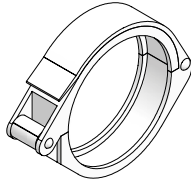

Fig. 68.3 Lever coupling SK-H

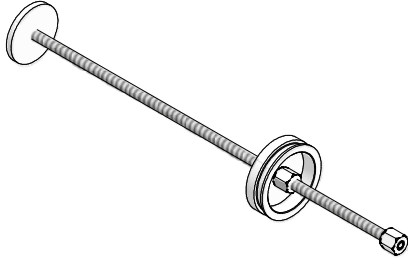

Fig. 68.4 Filling nozzle cleaner SK

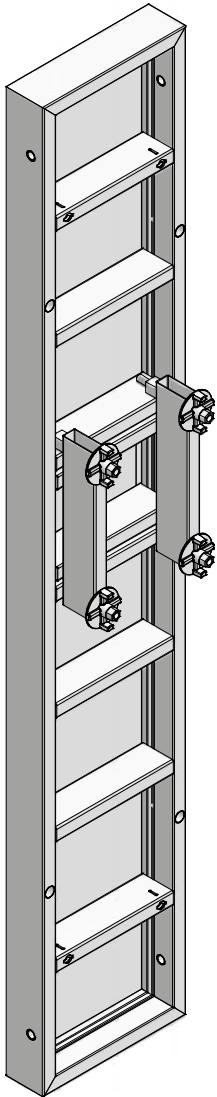

Fig. 68.6 Panel with concreting window

Description	Ref. No.
ST panel AL 17 270/45 with filling nozzle.....	21-213-55
with concreting window.....	21-213-60
Manual gate valve SK	
100 - 4½	29-914-50
125 - 5½	29-914-45
Filling nozzle cleaner SK	
100/800	29-207-50
125/800	29-207-55
Lever coupling SK-H	
DN 100 - 4½	29-207-60
DN 125 - 5½	29-207-65
Seal A SK 100 - 4½.....	62-031-55
Seal A SK 125 - 5½.....	62-031-56

Description	Quantity
ST panel AL 17, 270/ 45 with filling nozzle	1
Manual gate valve SK	1
Seal A SK	2
Lever coupling SK-H	2
Filling nozzle cleaner SK	1

Table 68.5 Material required for a panel with filling nozzle

Circular formwork

Circular buildings can be formed polygonally with standard panels, radius panels and tensioning bows (Figures 69.1 and 69.2).

The ties are inserted through the radius panels. The load is transferred through the tensioning bows. The minimum radius is 1.75 m.

When extending the panels on top of each other, the panels need to be connected with two assembly locks.



Fig. 69.1

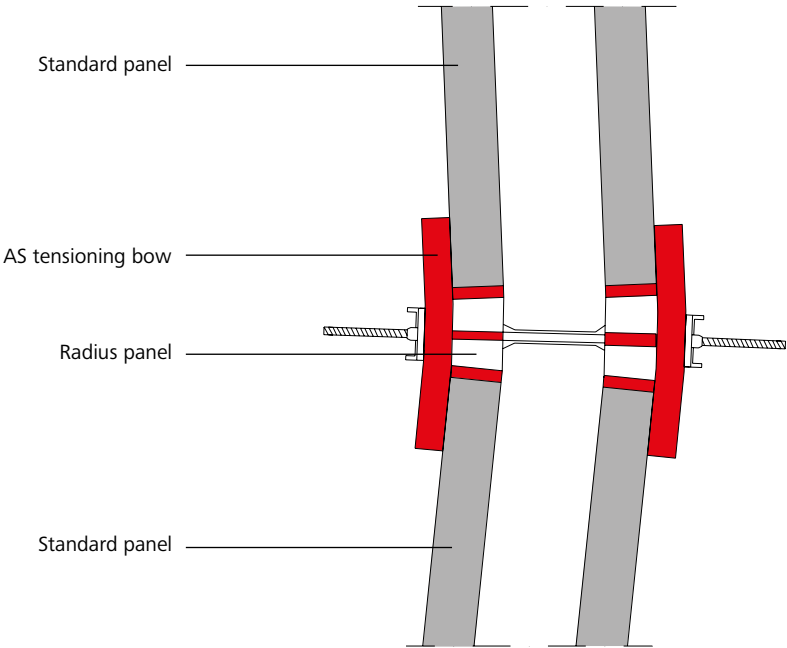

Fig. 69.2

Description	Ref. No.
AluStar radius panels	
AluStar RP 270/15	71-500-00
AluStar RP 270/20	71-500-10
AluStar RP 270/25	71-500-20
AluStar RP 135/15	71-500-40
AluStar RP 135/20	71-500-50
AluStar RP 135/25	71-500-60
AS tensioning bow.....	21-500-95

Circular formwork

When planning formwork for a full circle, ensure there are sufficient Uni-assembly locks 22 and timber fillers for compensation.

When forming pitch circles, make sure that the formwork can overlap for the next cycle or for stop ends.

A functional polygonal formwork requires the inside and outside formwork to be planned in proportion to each other.

Using panels with a smaller width allows the curved wall to fit the circle more exactly. This reduces the height of arch h (Fig. 70.1 and Table 70.2).

Height of arch (h) in cm for different radii and panel widths

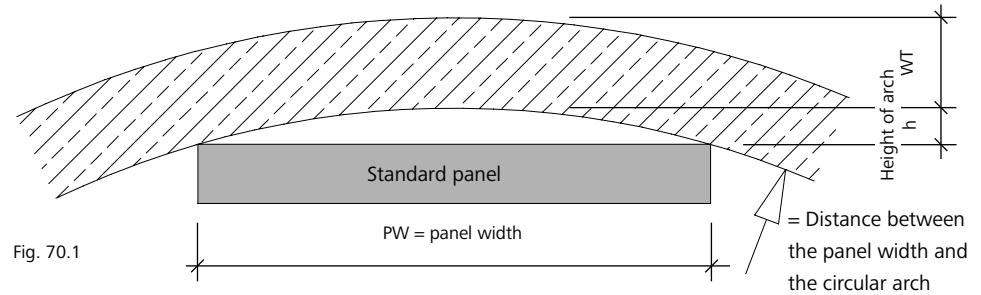

$$h = r_i - \sqrt{r_i^2 - (\frac{PW}{2})^2}$$

- WT = wall thickness
- h = height of arch
(Vertical distance between the middle of the panel and the circular arch)
- ri = inside radius

Table to determine the height of arch h in cm (depending on the wall radius and panel width)

Wall radius r_i [m]	Panel width PW [cm]								
	25	30	40	45	50	55	75	90	135
1.75	0.45*	0.64*	—	—	1.80**	—	—	—	—
2.00	0.39	0.56	1.00	1.27	1.57	—	—	—	—
2.50	0.31	0.45	0.80	1.01	1.25	1.55	—	—	—
3.00	0.26	0.37	0.66	0.85	1.04	1.26	—	—	—
3.50	—	0.33	0.57	0.72	0.89	1.08	2.00	—	—
4.00	—	0.28	0.50	0.63	0.78	0.95	1.76	—	—
4.50	—	0.25	0.44	0.56	0.69	0.84	1.56	—	—
5.00	—	0.22	0.40	0.51	0.63	0.76	1.41	2.03	—
6.00	—	—	0.33	0.42	0.52	0.63	1.17	1.69	3.81
7.00	—	—	0.28	0.36	0.45	0.54	1.01	1.44	3.26
8.00	—	—	0.25	0.32	0.39	0.47	0.88	1.27	2.85
9.00	—	—	0.22	0.28	0.35	0.42	0.78	1.13	2.53
10.00	—	—	0.20	0.25	0.31	0.38	0.70	1.01	2.28
12.00	—	—	—	—	0.26	0.32	0.59	0.84	1.90
15.00	—	—	—	—	0.21	0.25	0.47	0.68	1.52
20.00	—	—	—	—	0.15	0.19	0.35	0.51	1.14

Table 70.2

* when using the AS radius panel with width = .../15
 * when using the AS radius panel with width = .../20

Further applications

STB support frame for single-sided formwork

The StarTec and AluStar formwork together with STB support frames can also be used when concrete has to be poured against earth, rock, an existing wall or the like, i.e. when a single-sided formwork is required.

STB 300 support frames allow for walls up to 3.30 m, while STB 450 support frames together with height extensions allow for wall heights of up to over 12 m (Fig. 71.1).

Please observe the Support Frame STB Technical Instruction Manual.

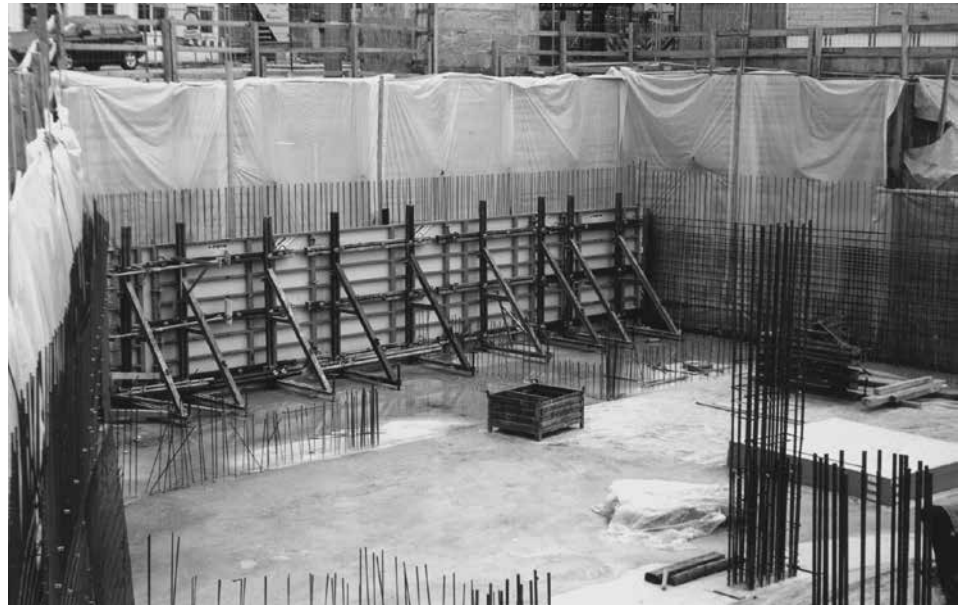

Fig. 71.1

KLK 230 climbing scaffold

When forming high walls, façades, pillars, and staircase or elevator shafts, the AluStar or StarTec formwork can be placed and secured on the KLK 230 climbing scaffold (Fig. 71.2).

Please observe the KLK 230 Climbing Scaffold Technical Instruction Manual.

Please note

The use of STB support frames and climbing scaffolds requires detailed formwork planning.

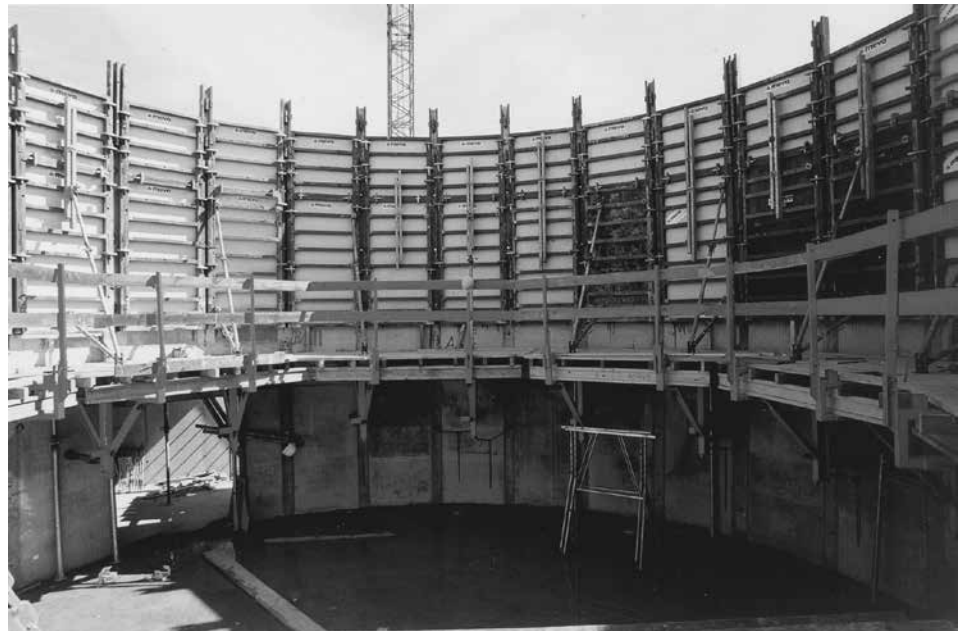

Fig. 71.2

Transport

Lifting hook 40

The lifting hook (Figures 72.1 and 72.3) can be used with any 4-rope crane sling on the construction site to transport StarTec panel stacks. Always use four hooks at once (Fig. 72.2). To calculate the admissible load-bearing capacity, assume that only two hooks are used.

Attention

A lifting hook must only be used if its eccentric is easy to turn or falls automatically into the locked position (Fig. 72.3). Never use a lifting hook if you need force to turn its eccentric. Turning the eccentric with force may not lock the lifting hook but only make it appear to be in the locked position. This may cause the lifting hook to slip when lifting the panel stack.

Technical data

- Weight 1.7 kg
- Max. load 10 kN (1 ton) per lifting hook
- Max. load 20 kN (2 tons) per panel stack
- Max. stack height: Five StarTec panels 270/240 or ten StarTec panels 270/135 and smaller

Repositioning

When moving panel stacks, make sure the panels are secured against sliding! MEVA secures them with safety bolts and, for truck transport, also with ratchet straps (see page ST/AS-74).

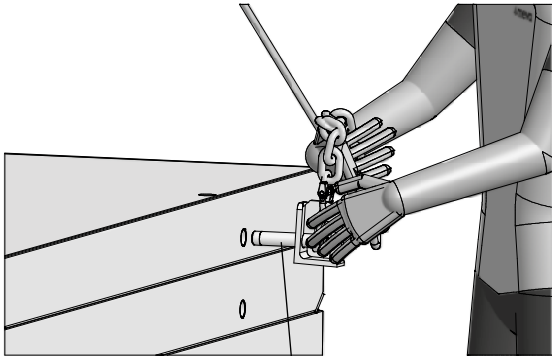

Fig. 72.1

Lifting hook

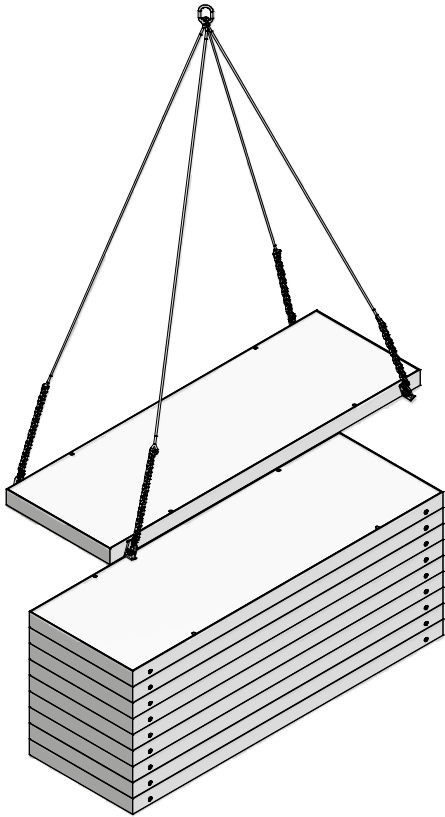

Fig. 72.2

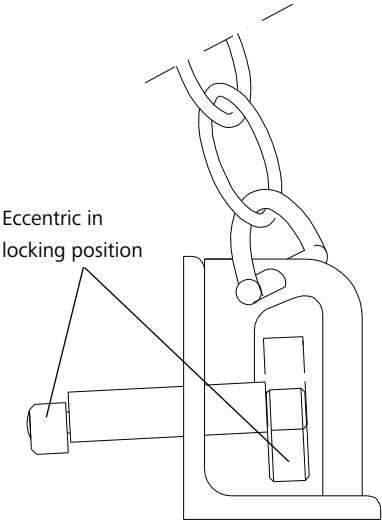

Fig. 72.3

Description	Ref. No.
Lifting hook 40	29-401-42

Transport

Stacking angle 60/40/23

With the stacking angle (Fig. 73.1) made of galvanized steel, two to five wall formwork panels of the same size with frame profile widths of 60 mm, 40 mm or 23 mm can be stacked and transported using a lift/pallet truck or a crane.

To use the stacking angle with StarTec/AluStar, the adjustable bracket on the stacking angle must be adjusted to suit the panel frame width of 40 mm (reference dimension = 44 mm) and attached using the two integrated M8 countersunk bolts with hexagonal nuts (Fig. 73.2).

Four stacking angles 60/40/23 are required for each panel stack (Fig. 73.3).

A maximum of three stacking units may be stacked one of top of the other for storage purposes (Fig. 73.3).

The permissible load capacity is:

- 15 kN (1.5 t) per stacking angle.
- 30 kN (3 t) when using four stacking angles (total load capacity).
- 45 kN (4.5 t) when using four stacking angles (total load capacity) if it has been ensured that the load is distributed evenly over further strands or if the permissible loading of the individual strands is not exceeded in the event of an unequal load distribution.

Assembly

1. Insert a stacking angle 60/40/23 at each corner of the StarTec/AluStar panel so that the panel lies on the supporting surface with the facing side upwards. This protects the facing when it is being moved by a forklift truck.
2. Insert the next panel into the adjustable brackets from above. The second panel secures the stack, which can now be moved.
3. If required, insert further panels (up to a total of five).

Note

- A 4-rope crane sling must always be used when transporting using a crane.
- The opening angle of the crane sling must not exceed 60° (Fig. 73.4).
- Observe the operating instructions for the stacking angle 60/40/23.

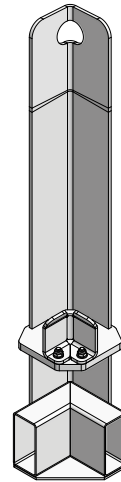

Fig. 73.1

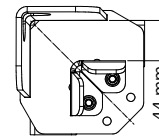
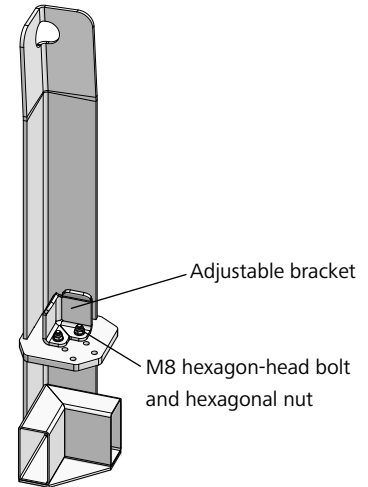

Fig. 73.2

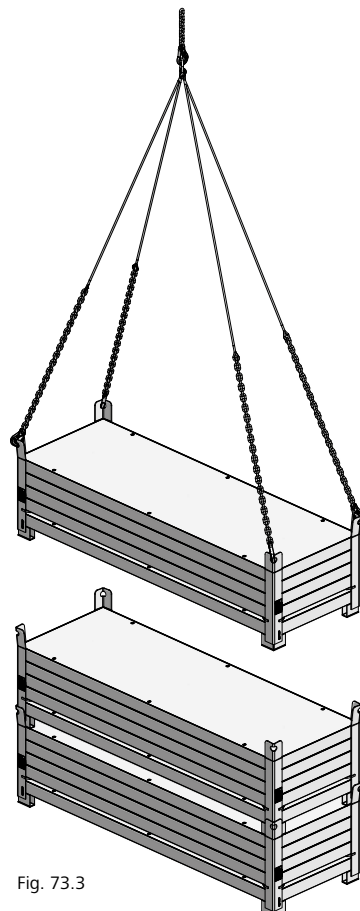

Fig. 73.3

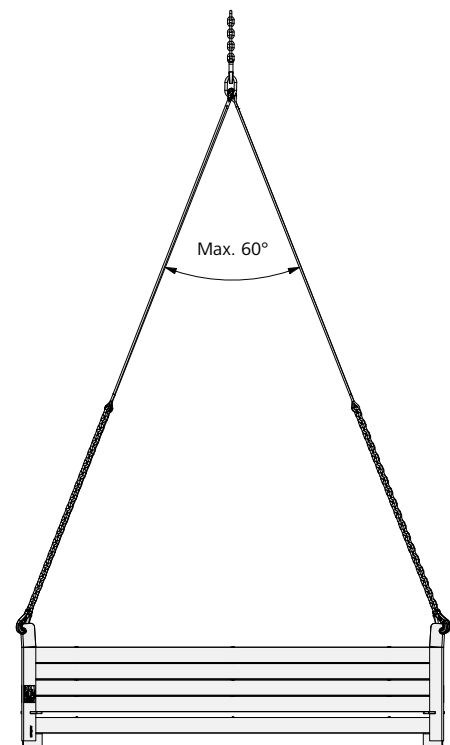

Fig. 73.4

Description	Ref. No.
Stacking angle 60/40/23	29-305-45

Wall Formwork

Transport

Make sure that all material is secured properly.

Transport guidelines

Use one ratchet strap per metre of cargo. This means that 14 ratchet straps are required for a fully loaded truck with a trailer length of 13.60 m.

Depending on their size, the ST/AS panels require two or three straps. Due to their lower weight, ST/AS corners require only two straps.

When moving panel stacks, make sure the panels are secure. MEVA secures the StarTec panels 270/240 with the grey ST 270/240 safety bolt and all other AluStar and StarTec panels with the black AS/ST safety bolt (Fig. 74.2).

These safety devices should also be used when returning the material from building site.

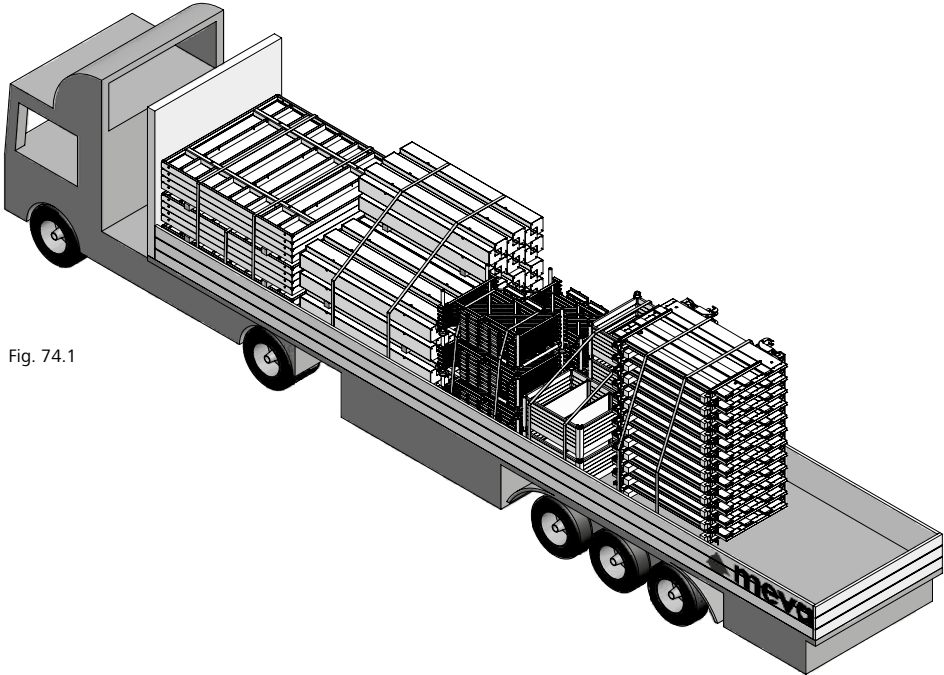

Fig. 74.1

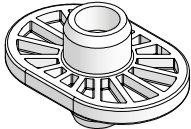

Fig. 74.2

Description	Ref. No.
Safety bolt	
AS/ST black.....	40-131-10
ST 270/240 grey	40-131-15

Wall Formwork

Services

Cleaning

The formwork is cleaned professionally using industrial equipment upon return.

Reconditioning

Reconditioning is carried out as follows: The frames are checked and, if necessary, blasted, coated with a high-quality cured powder coating, and provided with a new facing. As long as the formwork equipment still has its full load capacity, correct dimensions and is fully functional, reconditioning will always be a more economical solution than purchasing new formwork. Please note that the cleaning and reconditioning service is not available in all countries in which MEVA does business.

Rentals

As we have a comprehensive range of equipment in stock, we offer our customers the option of renting supplementary material at peak times. The MEVA logistics centre guarantees rapid delivery throughout Europe. We also give prospective customers the chance to test MEVA formwork so they can see its benefits for themselves in actual use.

RentalPlus

For a flat-rate fee MEVA's "fully comprehensive insurance" for rental formwork and equipment covers all secondary costs that occur after return (excludes losses and write-offs). For the customer this means: Costing certainty instead of additional charges, an earlier end of the rental period and thus lower rental costs because you save the time required for cleaning and repairs.

Formwork drawings

Our application engineers

worldwide work with CAD systems. This ensures that you always receive optimum formwork solutions and practice-oriented formwork and work cycle plans.

Special solutions

We can help with special parts, custom-designed for your project, to supplement our standard formwork systems.

Structural calculations

Generally, this is only necessary for applications such as single-sided formwork where the anchor parts are embedded in the foundation or the base slab. On request, we can perform structural calculations for such applications at an additional charge.

Formwork seminars

To ensure that all our products are used properly and efficiently, we offer formwork seminars. They provide our customers with a good opportunity to keep themselves up to date and to benefit from the know-how of our engineers.

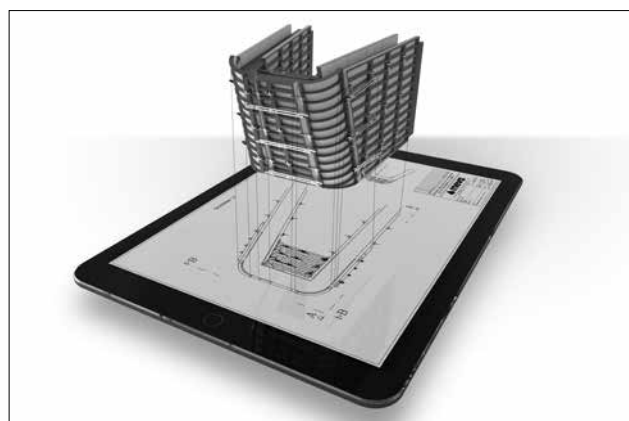
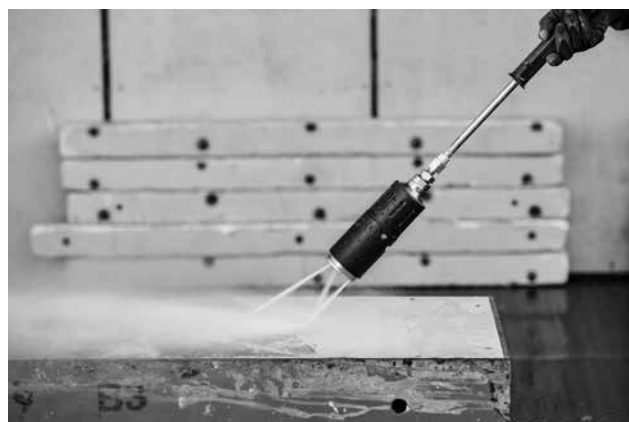

Notes

A large grid of small dots for taking notes, consisting of 20 columns and 30 rows.